

2020

[fleetwoodrv.com](http://fleetwoodrv.com)

CLASS A GAS | FORTIS



 **FLEETWOOD RV**  
FORTIS

2	INTRO	
4	CONSTRUCTION	
6	INTERIOR GALLERY	
10	FLOORPLANS AND EXTERIOR GRAPHICS	
11	DECOR	
12	STANDARDS AND OPTIONS	
14	OUTSTANDING STANDARDS AND OPTIONS SPECIFICATION CHARTS	



## INTRODUCE YOURSELF TO FLEETWOOD'S NEWEST MODEL.

This full-scale luxury gas Class A is the ideal companion for all of your adventures. Built on the Power Platform chassis for a strong foundation, smooth ride and incredible exterior storage, the Fortis abounds in standard features, including 22.5-inch tires and aluminum Alcoa wheels. You'll also enjoy better handling and control with the Bilstein® steering stabilizer system. When you step inside, the lavish amenities continue with convenience in the form of a Hide-A-Loft™ drop down queen bed, decorative touches like a stainless steel farmhouse sink, and technology—such as Android Auto and Apple CarPlay with Navigation integrated with the 10-inch display and a smart TV with Amazon Fire TV.

The Fortis is the perfect vehicle to get you out on the road in comfort and style.



FORTIS 33HB  
STARLIGHT GRAPHICS

**WE'LL BRING THE POWER,  
YOU BRING THE PEOPLE.**



**POWER  
PLATFORM**

**The Power Platform Chassis™**

The Power Platform puts strength, stability, and reliability front and center. Perfect for trips requiring large carrying capacities, and built to store everything you need with spacious pass-through storage, the Power Platform is the ideal chassis for optimum balance and control — Found on Fleetwood gas motorhomes.

Every new adventure requires a solid foundation. The Power Platform chassis is designed with balance, control, a smooth ride, and ample space in mind, all working together to give you a ride like no other RV can provide.

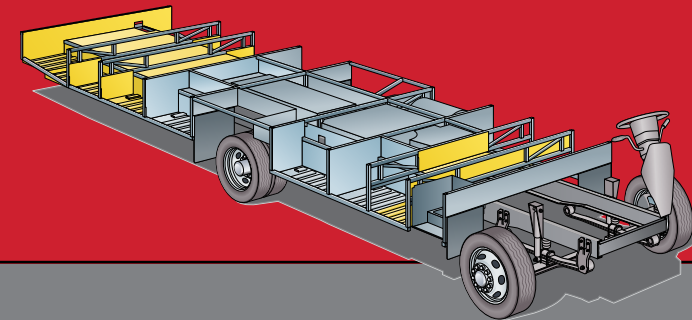

**RV OWNERCARE**

Limited one-year/15,000-mile coach warranty and three-year/45,000-mile structural warranty, whichever occurs first, and it is fully transferable for the first 12 months. RV OWNERCARE is one of the RV industry's most comprehensive programs and includes systems, appliances, components and construction, with no deductible and no service charge.

Chassis Warranty provided by Ford®

**FLEETWOOD RV**



**We build strength  
and quality from the  
inside out.**

Fleetwood's exclusive Powerlock™ system is integrated into all Fleetwood RV Class A Gas models.

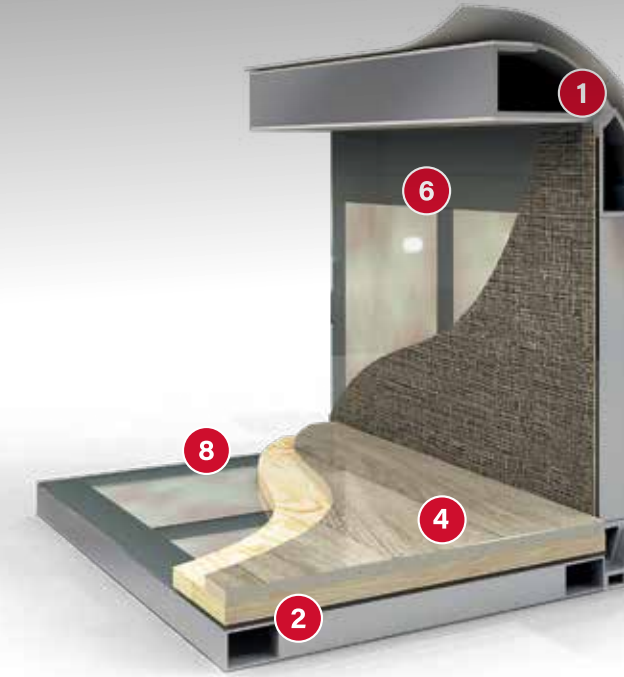

**At Fleetwood, we don't settle for anything less than the best and neither should you. That is why every Fleetwood features industry-leading materials and construction standards.**

- 1 PowerLock System™ Interlocking Walls and Ceiling**  
Fleetwood's interlocking aluminum extrusion wall-joint system integrates sidewall and roof assembly into one locked-together overall structure for long-term performance and durability.
- 2 Precision Welded Joints**  
The all aluminum hull structure is engineered and built to precise tolerances and then precision welded to ensure strength and durability on eventhe roughest road trip.

**At Fleetwood RV, it's not just what you see that matters. It's what you don't.**

- 3 Tuff-Coat Fiberglass Walls**  
Thicker than other manufacturers, our Tuff-Coat fiberglass walls provide a durable skin and is the perfect surface for an automotive style finish.
- 4 Thick Robust Floor**  
Thicker than the industry standard, Fleetwood engineered the 1" thick floor for more sound deadening and more insulation which results in a quieter, more comfortable ride no matter the weather or terrain outside.
- 5 Solid Bead-Foam Insulation™**  
Fleetwood's above-standard insulation material and process doesn't allow settling or air gaps to form. There is no forcing the precision cut insulation into position like the roll-type pink fiberglass insulation used by other manufacturers.
- 6 Loctite® Industrial Adhesive**  
Engineered to meet bonding, sealing and assembly requirements for a durable structure with no de-lamination.
- 7 No Wood Substrate**  
Unlike most Class A motorhome manufacturers, you won't find any wood substrate on the exterior walls.
- 8 1/2" Plywood Subfloor**  
Thicker than most competitors who use OSB or chip board, the integrated 1/2" subfloor provides a solid surface for flooring and eliminates movement and flexing while traveling.
- 9 Vacu-Bond™ Construction**  
Fully sealed and weather-resistant, the vacuum-bonded assemblies combine materials and construction for a straight, solid integrated wall that is better suited to withstand the rigors of the road. An adhesive bonding process applies up to 415,000 pounds of vacuum pressure to the welded-aluminum sidewall frame, bead-foam insulation, thick Tuff-Coat fiberglass skin and inner wall materials, far exceeding industry standards.
- 10 CNC Precision Routed Walls and Floors**  
Computer driven routers precisely route walls and floors to fit exact specifications to eliminate gaps, misalignments and provide for a more solid integrated overall structure.



**Each of these advantages have been engineered to deliver superior reliability, durability and most of all, customer satisfaction.**



## FORTIS

33HB | 34MB

FORTIS 33HB  
Shown in Santorini decor  
with Cappuccino cabinetry



FORTIS 33HB  
Shown in Santorini decor  
with Cappuccino cabinetry

**FLEETWOOD RV**  
Build your own Fortis at  
[fleetwoodrv.com/build-your-own](http://fleetwoodrv.com/build-your-own)

**33HB**

Options:  
089, 096, 105,  
126, 131, 173,  
194, 230, 304,  
435, 447, 485,  
580, 605, 953

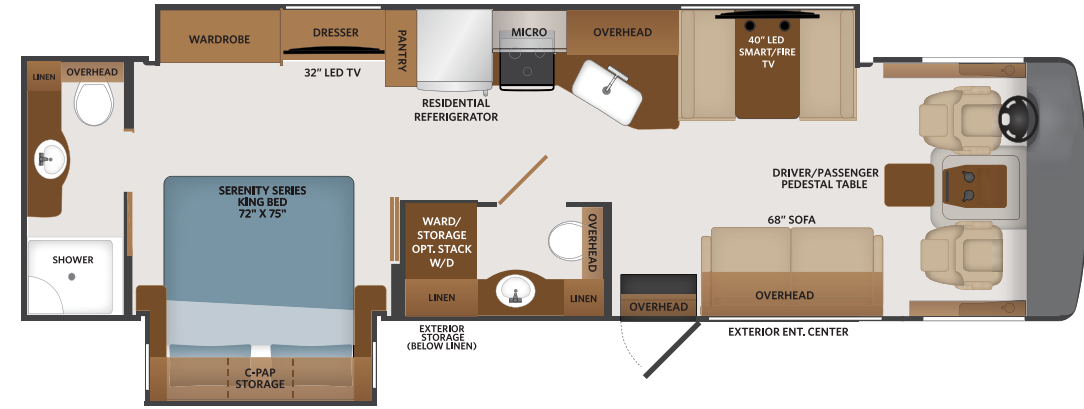

**34MB**

Options:  
089, 096, 105,  
126, 131, 173,  
194, 230, 304,  
435, 447, 485,  
580, 605, 953

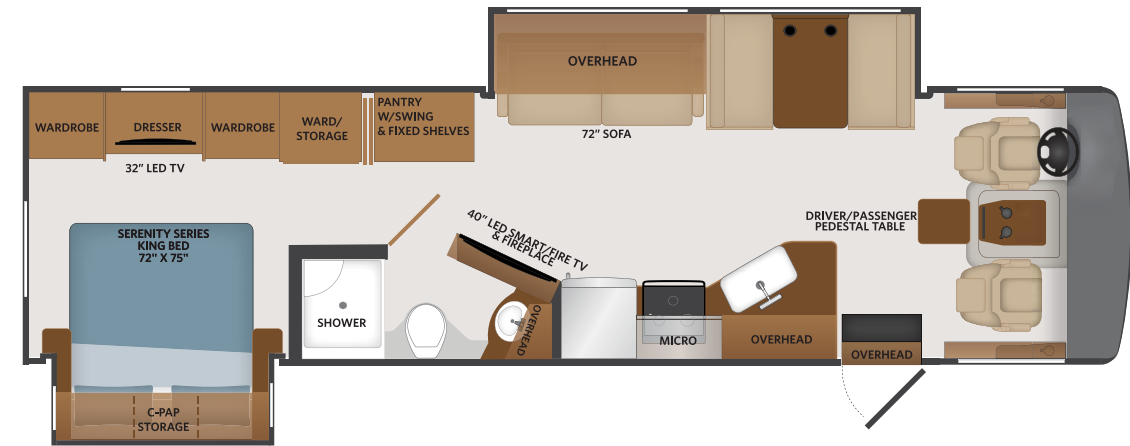

AVAILABLE OPTIONS

	126 WASHER/DRYER COMBO	089 UPGRADED WIFI PACKAGE LTE (CELLULAR INTERNET MODEM)	230 ROOF VENT RAIN COVERS
	131 WASHER/DRYER STACKABLE	096 UNIVERSAL KING ONE SATELLITE SYSTEM	304 SOLAR ELECTRICAL PANEL
	194 THEATRE SEATING SOFA	105 DOMETIC 8' CF DOUBLE DOOR REFRIGERATOR LP	435 CSA-PACKAGE FORD®
		126 WASHER/DRYER - ALL IN ONE COMBO	447 CSA-FORD® INSTRUMENT PANEL
		131 WASHER/DRYER - STACKABLE	485 BLIND SPOT DETECTION
		173 CELLULAR BOOSTER	580 COLLISION MITIGATION
		194 THEATRE SEATING SOFA	605 DUAL GLAZED WINDOWS
			953 POWER DRIVER SEAT

PARTIAL PAINT STANDARD



Khaki



Starlight



Build your own FORTIS at [fleetwoodrv.com/build-your-own](http://fleetwoodrv.com/build-your-own)

INTERIOR DECOR

Manhattan

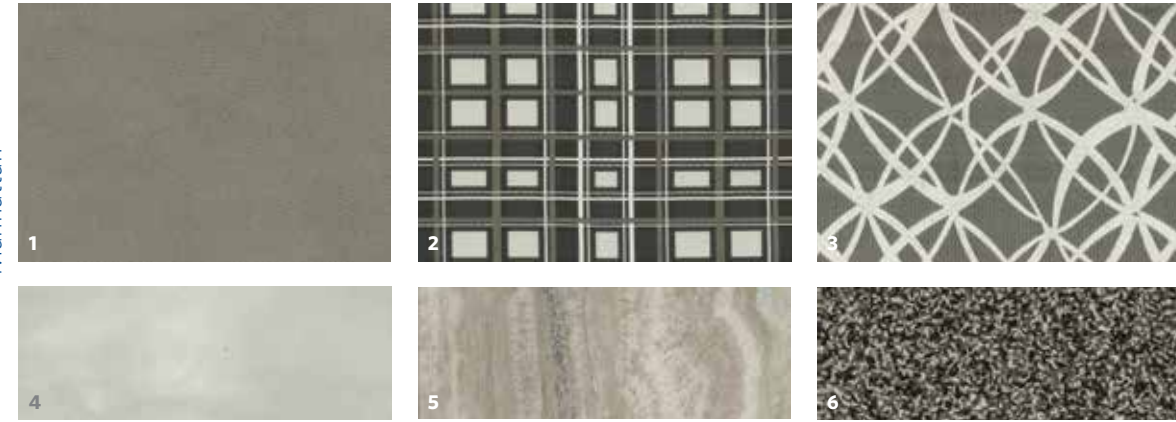

Midtown



Santorini

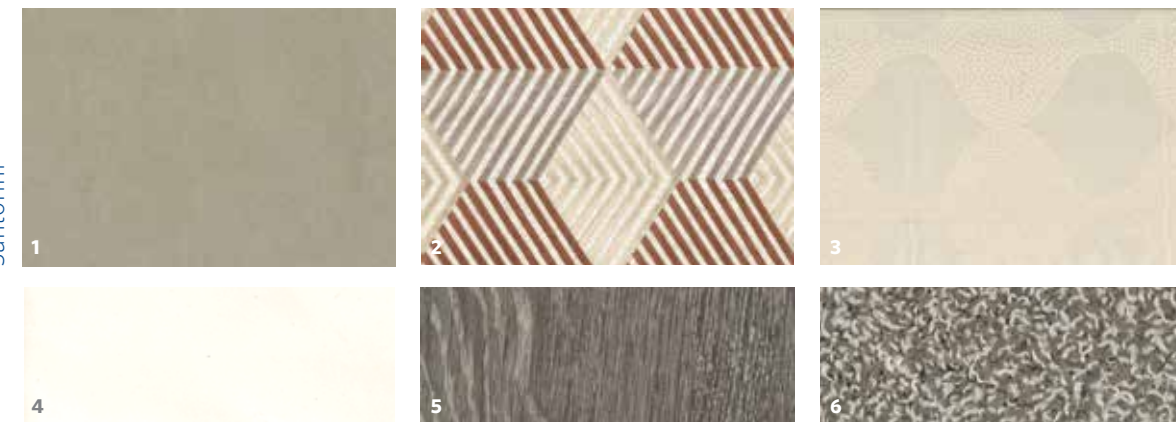

1 SOFA  
2 LIVING ACCENT

3 BEDSPREAD  
4 COUNTERTOP

5 FLOORING  
6 CARPET

CABINETRY



Cappuccino



Greystone



Oxford

Fortis interior designer recommends:

- Manhattan décor with Greystone Cabinetry
- Santorini décor with Oxford or Cappuccino Cabinetry
- Midtown décor with Greystone or Oxford Cabinetry

Create a customized look that reflects your personal style.

EXTERIOR	33HB	34MB
Aerodynamic Fiberglass Cap w/Hood and Automotive Headlighting	S	S
Rear Fiberglass Cap w/Automotive Lighting	S	S
ABS Wheel Well Trims	S	S
TPO Roof - Thermoplastic Polyolefin	S	S
Legged Electric Patio Awning w/LED Lighting	S	S
Radiused Entry Door w/Screendoor, Strut, Latch, Deadbolt Lock	S	S
Slide Out Awning Toppers Above All Slideouts	S	S
Slam Latch Luggage Door Handles - Black	S	S
Entry Grab Handle	S	S
Power Entry Step w/Light	S	S
Bottom/Side Swing Radiused, Color Matched Fiberglass Luggage Doors	S	S
Single Pane Frameless Windows	S	S
Dual Pane Frameless Windows	O	O
Patio LED Light	S	S
Front, Side and Rear Clearance and Marker Lighting	S	S
Gravity Fresh Water Fill	S	S
Enclosed Exterior Waste Station w/Discharge Valves	S	S
Trailer Hitch w/7-Way Round Tow Connection (8,000 lbs.)	S	S
TV Antenna - Unidirectional King Controls Jack Antenna	S	S
LP Connection	S	S
Four Point Fully Automatic Hydraulic Leveling Jacks	S	S
Rear Ladder	S	S
Partial Paint w/Vinyl Graphics	S	S
Roof Vent Rain Covers	O	O
Roof Mount Satellite Dish Prep	S	S
KING Universal Satellite System	O	O
CAB EXTERIOR	33HB	34MB
Automotive One Piece Windshield	S	S
Daytime Running Lights	S	S
Driver/Passenger Slider Windows	S	S
Fog Lamps	S	S
Automotive Style Windshield Wiper System	S	S
Remote Power/Heated Mirrors w/Turn Signals and Side Cameras - Chrome/Black	S	S

Blindspot Detection	O	O
CAB INTERIOR	33HB	34MB
Driver Chair w/Reclining Back, Swivel and Manual Controls	S	S
Driver Chair w/Reclining Back, Swivel and 6-way Power Controls	O	O
Passenger Chair w/Reclining Back, Swivel and Manual Controls	S	S
Driver/Passenger ABS Style Armrests	S	S
Cupholders - Driver/Passenger	S	S
Power Windshield Roller Shade	S	S
Window Manual Roller Shades - Driver/Passenger	S	S
Overhead Map Lighting - Driver/Passenger	S	S
Black Instrument Gauges w/Electronic Information Center	S	S
High Output Dash Air Conditioning and Heat	S	S
Electronic Cruise Control	S	S
Windshield Wipers w/Delay	S	S
Remote Switch for Power/Heated Mirrors	S	S
Steering Wheel w/Tilt Column	S	S
6" Color Monitor for Side and Rear Cameras	S	S
10" Alpine® Stereo w/AM/FM/Bluetooth®/MP3/USB - Phone Control - Android Auto & Apple CarPlay w/Navigation - Siri Eyes Free - Built in HD Radio - Apps (Waze, Spotify, Amazon Music) - Sirius/XM Ready (Requires Subscription) - Backup Camera	S	S
USB and Auxiliary Inputs	S	S
Seat Belts - 3 Point Driver & Passenger w/Adjustable Straps	S	S
12V Accessory Ports	S	S
110-Volt AC Outlets	S	S
Automotive Style Dash w/Dual Monitors and Workstation	S	S
Generator On/Off Switch	S	S
Colored Fiberglass Engine Cover w/Snack Tray	S	S
Auto Leveling Jack Controls	S	S
Driver/Passenger Center Table	S	S
Auxiliary Start Switch	S	S
Hide-A-Loft™ Drop Down Queen Bed	S	S
INTERIOR	33HB	34MB
Sofa - Jack-knife	S	S
Sofa - Theatre Seating	O	O
Facing Booth Dinette w/Dream Dinette Table w/Single Door Storage	S	S
Solid Surface Galley Top w/Sink Covers	S	S

Surf-X Tops Throughout (Excluding Galley)	S	S
Electric Fireplace	—	S
Feature Wall w/Accent Wall Covering	S	S
Feature Wall w/Surf-X Covering	—	S
Flat Ceiling w/Soft Touch Vinyl	S	S
Vinyl Tile Flooring Throughout	S	S
Non-Ozite Lined Cabinet Interiors w/Adjustable Shelving	S	S
Full Extension Drawer Guides w/Latches	S	S
Hidden Euro Hinges and Struts	S	S
Cabinet Doors - Solid Wood, Raised Panel	S	S
Galley Overhead Glass Inserts	S	S
Slideout Fascia - Hardwood Interior Wood Color Coordinating	S	S
Valances w/Lambrequins	S	S
Manual Night Roller Shades	S	S
Energy Efficient 3" LED Flush Mount Ceiling and Under Cabinet Reading Lights Throughout	S	S
Chrome Faucets/Fixtures/Hardware	S	S
INTERIOR ENTRY	33HB	34MB
Battery Disconnect	S	S
Interior Entry Grab Handle - Metal	S	S
Solid Surface Entry Steps	S	S
KITCHEN	33HB	34MB
Refrigerator - Residential Stainless Steel - Insignia	S	S
Refrigerator - LP 8 cu.ft. - Dometic	O	O
Cooktop - 3-Burner	S	S
Stainless Steel Over the Range Convection Microwave	S	S
Tile Backsplash	S	S
Sink - Stainless Steel Farmhouse-Style	S	S
Residential Single Handle Faucet w/Pullout Sprayer	S	S
Adjustable Shelves Throughout	S	S
Power Ceiling Vent	S	S
BEDROOM	33HB	34MB
King Bed	S	S
Designer Bedspread, Headboard, Pillow Shams & Pillows	S	S
C-PAP Machine Prep in Bedroom Overhead	S	S

120V/USB Ports	S	S
Reading Lights	S	S
LAVY	33HB	34MB
Sink - Top-Mounted Stainless Steel	S	S
Residential Faucet - Single Handle	S	S
Medicine Cabinet w/Mirror	S	S
ABS Shower Surround	S	S
Glass Shower Door	S	S
Shower Skylight	S	S
Metal Shower Head w/Sliding Adjustable Bar, Soap Dish and Matching Single Valve Faucet	S	S
Standard Toilet - Porcelain	S	S
Macerator Toilet - Porcelain	S	—
Power Ceiling Vent	S	S
ENTERTAINMENT	33HB	34MB
32" Flat Screen LED TV (Bedroom)	S	S
39" Flat Screen Smart/Fire TV LED TV (Living Area)	S	S
Living Area Ceiling Speakers	S	S
Bluetooth® Coach System in Bedroom w/Exterior Speakers	S	S
Exterior Entertainment Center w/50" LED TV	S	S
ELECTRIC & UTILITIES	33HB	34MB
A/C - Dual 13,500 BTU	S	S
Furnace - 30,000 BTU	S	—
Furnace - 34,000 BTU	—	S
50 Amp Service	S	S
55 Amp Power Converter	S	S
Inverter - Single 2000w	S	S
WiFi Ranger™ Sky4	S	S
WiFi Ranger™ SkyPro Pack	O	O
Solar Panel - 100w	S	S
Multiplex Wiring Control System w/4.3" Touchscreen Panel	S	S
6V Aux Batteries (4)	S	S
Generator - 5.5kW Onan Quiet	S	S
Auto Gen Start	S	S
Master Battery Disconnect Switch	S	S

Water Pump - 12V 3GPM High Capacity Shurflo Water Pump	S	S
Water Purification System	S	S
Water Heater Bypass System	S	S
City Water Hookup	S	S
Exterior Shower	S	S
Cable TV/Satellite Hookup	S	S
Black Holding Tank Flush System - San-T-Flush	S	S
Single Location Monitor panel w/LPG, Touch Sensor Tank Monitoring/Battery Readouts	S	S
Fire Extinguisher, LP/CO and Smoke Detectors	S	S
GFCI Receptacle in Exterior Storage	S	S
Washer/Dryer Prep - Combo	S	S
Washer/Dryer - Combo	O	O
Washer/Dryer - Stackable	O	O

\*\*CSA Standards may require substitution or deletion to achieve conformance

### FORTIS TECHNOLOGY & SAFETY — STANDARDS & OPTIONS

WiFiRanger™Sky4 DC	S
WiFiRanger™Sky4 ProPack w/LTE (Cellular Internet Modem) Includes Cell Booster and GPS Upgrade	O
10" Alpine Stereo w/AM/FM/Bluetooth/MP3/USB - Phone Control - Android Auto & Apple CarPlay w/Navigation - Siri Eyes Free - Built in HD Radio - Apps (Waze, Spotify, Amazon Music) - Sirius/XM Ready (Requires Subscription) - Backup Camera -	S
Solar Panel 100w	S
Solar Panel 265w	O
Velvac® Blind Spot Detection in Mirror	O

### DEEP ADDITIONAL STORAGE AND CLOSET SPACE

This innovative feature functions like a lazy susan with the additional pantry item shelf storage and with a simple turn of the door to reveal behind a large shelving stow area. Available on the 34MB floorplan only.



FORTIS — OUTSTANDING STANDARDS AND OPTIONS



**RENEWABLE SAFE POWER**  
Each FORTIS is pre-wired for a solar panel which allows the adding of an after market solar panel.

**WIFI RANGER™ SKY4 DC**  
Boost a weak signal to get online in no time with this private secure WiFi booster.

**WIFI RANGER™ SKY4 PROPACK w/LTE**  
Upgrade to this cellular internet modem that includes a cell booster and GPS upgrade.



**BONDED WINDSHIELD**  
Feel safer with this automotive style curved bonded windshield. This automotive inspired design bonds the windshield along the entire perimeter of the glass. This increases the structural strength and also reduces the risk of stress cracks.



**KING EURO TOP MATTRESS**  
Sleep like royalty in this spacious 76" x 72" luxurious residential style bed with a euro top mattress.



**EXTERIOR ENTERTAINMENT CENTER**  
Every Fortis is standard equipped with an exterior entertainment center with 50" LED TV for additional entertaining space.



**HIDE-A-LOFT™ DROP DOWN BED**  
Invite more guests on your road trip without compromising space with this queen bed, featuring industry-leading headroom and up to 600lb capacity.



**BLIND SPOT DETECTION (OPTIONAL)**  
Ensure smart, safe driving with Velvac® blind-spot upgraded mirrors for your Fortis. A safety feature, where a light will illuminate on the side mirror if an object is in the blind spot ensuring safe travels. Fortis comes standard with remote power, heated mirrors with turn signals and side cameras.



**AUTO GENERATOR START**  
Batteries need charging? A/C needs to kick on? This feature will automatically turn on your generator to give them some juice and then turn off when they have enough charge.



**AUTO HYDRAULIC LEVELING SYSTEM (STANDARD)**  
Save time and avoid hassle by leveling and stabilizing your RV with the push of a button.



**BILSTEIN® STEERING STABILIZER SYSTEM (STANDARD)**  
Every Fortis is standard equipped with this shock absorber system that dampens the bumps and vibrations of the road in the steering system. Bilstein allows for easier control to the front-end steering.



**ALCOA® WHEELS (STANDARD)**  
Every Fortis is standard equipped with Alcoa wheels. Alcoa wheels are designed for increased load requirements. Not only do these wheels look good but they are made to last for the long haul with less maintenance.

**WASHER/DRYER OPTIONS (UPGRADE)**  
All the amenities of home-sweet-home with washer and dryer options available. Choose from an all-in one combo unit or a stackable unit conveniently tucked away in the master bedroom.



**OUR VERY OWN FLEETWOOD RV MOTORHOME SERVICE CENTERS**

At Fleetwood RV, we strive to deliver peace-of-mind at every turn. Our devotion to customer service starts with our trusted dealer network and spans to our own staff of motorhome service professionals at REV Recreation Group's regional technical centers. The motorhome service centers are strategically located throughout the United States to provide you convenient service wherever the road takes you.

Below, you'll find the closest motorhome service center, as well as a list of the other centers. Please visit [www.fleetwoodrv.com/motorhome-service-centers](http://www.fleetwoodrv.com/motorhome-service-centers) to schedule a Service Appointment.

East Coast  
REV Technical Center  
800-509-3417

West Coast  
REV Technical Center  
877-466-6226

**ROADSIDE ASSISTANCE. ANYWHERE. ANYTIME.**

24/7 CUSTOMER SUPPORT FOR:  
• FUEL • TOWING  
• BATTERY • SLIDE-OUT ISSUES  
• LOCKSMITH • AND MUCH MORE!

1-855-268-0414



One-year of REV Assist is free with the purchase of any new 2020 Fleetwood. You may extend your coverage after the first year at [www.revgroup.com/rev-assist](http://www.revgroup.com/rev-assist).

**FORTIS**

CHASSIS	33HB	34MB
Wheelbase (inches)	228"	242"
Front GAWR (lbs)	8,000	8,000
Rear GAWR (lbs)	15,000	15,000
GCWR (lbs)	26,000	26,000
GVWR (lbs)	22,000	22,000
Hitch Rating Weight (lbs)	8,000	8,000
Tongue Weight (lbs)	800	800
Fuel Capacity (gal)	80	80

**DIMENSIONS AND CAPACITIES**

	33HB	34MB
Overall Length (inches)	35' 3"	35' 9"
Overall Height (with A/C)	12' 10"	12' 10"
Overall Width (maximum)	100"	100"
Interior Height (maximum)	82"	82"
Interior Width (maximum)	96"	96"
Patio Awning Width (ft./in.)	14'	20'
Interior Storage (cu. ft.)	152	128
Exterior Storage (cu. ft.)	145	134
Fresh Water Holding Tank (gal)	100	100
Grey Water Holding Tank (gal)	50	50
Black Water Holding Tank (gal)	50	50
Appliance Propane Tank (gal) (WC)	25	25
Water Heater Tank (gal)	10	10

Product information, photography and illustrations included in this publication were as accurate as possible at the time of printing.

**FORD® CHASSIS**

Model: Ford®  
Engine: 6.8L Triton V10  
Transmission: Ford® 6-Speed, Automatic w/Overdrive  
Alternator: 175 Amp  
Torque: 460 lb.-ft. @ 3,000 RPM  
Horsepower: 320HP @ 3,900 RPM



**DISCLAIMERS**

- GVWR (Gross Vehicle Weight Rating) is the maximum permissible weight of this fully loaded motorhome. The GVWR is equal to or greater than the sum of the (UVW) unloaded vehicle weight plus the (OCCC) occupant cargo-carrying capacity.
- GAWR (Gross Axle Weight Rating) is the maximum permissible loaded weight a specific axle is designed to carry.
- GCWR (Gross Combined Weight Rating) is the value specified by the motor home manufacturer as the maximum allowable loaded weight of this motorhome with its towed vehicle. Towing and braking capacities may be different. Refer to Fleetwood and chassis manufacturer's manuals for complete information.
- Length measured from front bumper to rear bumper (excludes accessories).
- Excludes safety equipment and awnings.
- Motorhomes feature a body width over 96" which will restrict your access to certain roads. Before purchasing, you should research any state and/or province road laws which may affect your usage.
- Tank manufacturer's listed water capacity (WC). Actual propane capacity is 80% of water listing as required by the safety code.
- † The chassis manufacturer recommends the installation of a supplemental brake control system to activate the brakes on the vehicle or trailer you are towing. Hitch receiver ratings expressed are maximum for the hitch receiver installed and may require the purchase of additional equipment that is dependent on the weight of the towed load. Consult with hitch receiver manufacturer for further information.
- \* UVW and OCCC are found on the label containing the federal certification tag in each RV.
- \*\* Seatbelts and locations are shown in the brochure for display purposes only. Actual numbers and locations will vary by model.
- \*\*\* All 2020 REV Recreation Group motorhomes include a limited one year/15,000-mile coach warranty and three-year/45,000-mile structural warranty, whichever occurs first, and is fully transferable for the first 12 months.

**FLEETWOOD MOTORHOME ASSOCIATION**

As a Fleetwood RV owner, you're invited to become a member of the Fleetwood Motorhome Association (FMA). Becoming a member is the perfect way to meet other Fleetwood owners who love to travel across America and share in the RV lifestyle. Visit the FMA website at [www.fma4fun.org](http://www.fma4fun.org) to learn more and join the fun.

**CONTACT US**

To locate a dealer near you, visit our website at [www.fleetwoodrv.com](http://www.fleetwoodrv.com) or call 1-800-322-8216. We can also be contacted at Fleetwood RV Customer Relations, P.O. Box 1007, Decatur, IN 46733.

**IMPORTANT—PLEASE READ:** Product information, photography and illustrations included in this publication were as accurate as possible at the time of printing. For further product information and changes, please visit our website at [www.fleetwoodrv.com](http://www.fleetwoodrv.com) or contact your local Fleetwood RV dealer. Prices, materials, design and specifications are subject to change without notice. All weights, fuel, liquid capacities and dimensions are approximate. Fleetwood RV has designed its recreational vehicles to provide a variety of uses for its customers. Each vehicle features optimal seating, sleeping, storage and fluid capacities. The user is responsible for selecting the proper combination of loads (i.e., occupants, equipment, fluids, cargo, etc.) to ensure that the vehicle's capacities are not exceeded.

Visit our website for more photos and to build your 2020 Fortis at [fleetwood.com](http://fleetwood.com).



YOUR LOCAL DEALER



Fleetwood RV is part of REV Recreation Group, a division of REV Group, Inc., a family of 29 industry-leading motor vehicle brands. At REV Group, we innovate, design and build products that connect and protect thousands of people every day—our trusted vehicles are engineered with the utmost rigor and precision to deliver the highest levels of performance, reliability, durability and safety.



IMPORTANT—PLEASE READ: Product information, photography and illustrations included in this publication were as accurate as possible at the time of printing. For further product information and changes, please visit our website at [www.fleetwoodrv.com](http://www.fleetwoodrv.com) or contact your local Fleetwood RV dealer. Prices, materials, design and specifications are subject to change without notice. All weights, fuel, liquid capacities and dimensions are approximate. Fleetwood RV has designed its recreational vehicles to provide a variety of uses for its customers. Each vehicle features optimal seating, sleeping, storage and fluid capacities. The user is responsible for selecting the proper combination of loads (i.e., occupants, equipment, fluids, cargo, etc.) to ensure that the vehicle's capacities are not exceeded.

[www.fleetwoodrv.com](http://www.fleetwoodrv.com)

©2019 REV Group, Inc. Printed in the USA. 11/19. Model Year 2020, First Edition.

Part #: L93-0030-20