

Southwind[®]

BY FLEETWOOD[®]

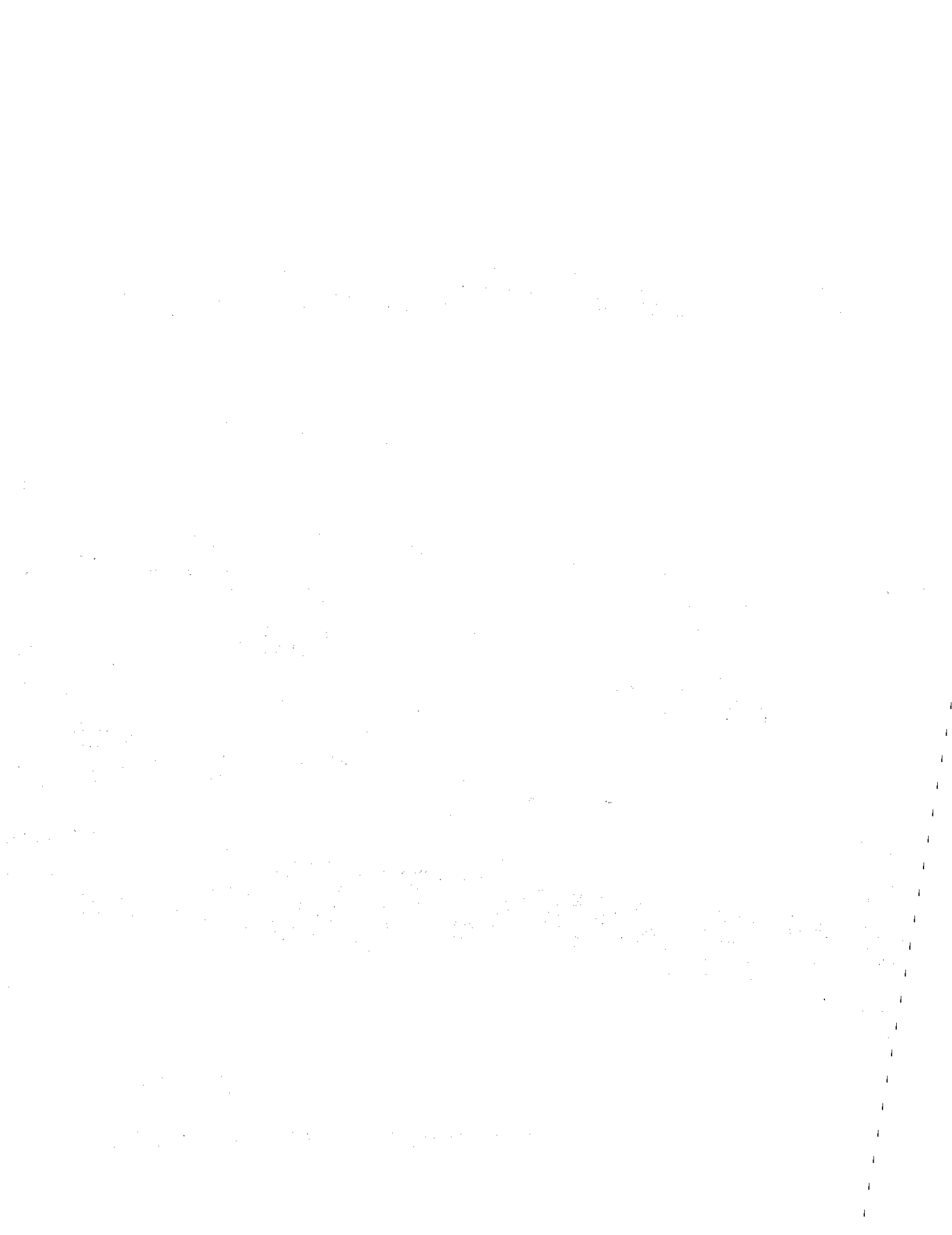

1995
owner's manual



This page intentionally left blank.

This page intentionally left blank.

Southwind[®]
BY FLEETWOOD.

1995

This page intentionally left blank

FULL ONE-YEAR / 15,000 MILE

WARRANTY

FOR MOTOR HOMES MANUFACTURED BY SUBSIDIARIES OF FLEETWOOD ENTERPRISES, INC.
SOLD IN THE UNITED STATES AND CANADA

COVERAGE PROVIDED

Your new motor home, including the structure, plumbing, heating and electrical systems, and all appliances and equipment installed by the manufacturer, is warranted under normal use to be free from manufacturing defects in material or workmanship.

The warranty extends to the first retail purchaser and his transferee(s) and begins on the date of original retail delivery or the date the motor home is first placed into service as a rental, commercial or demonstrator unit (whichever occurs first). The warranty extends for a period of one year from such date or until the unit has received 15,000 total miles of use as determined by the mileage shown on the odometer (whichever occurs first). Written notice of defects must be given to the selling dealer or the manufacturer not later than ten (10) days after the expiration of the warranty period.

OWNER'S OBLIGATIONS

The owner is responsible for normal maintenance as described in the Owner's Manual; however, minor adjustments (such as adjustments to the interior or exterior doors, LP regulator pressure, cabinet latches, TV antenna control, etc.) will be performed by the dealer during the first 90 days of warranty coverage. Thereafter, such adjustments are the responsibility of the owner as normal maintenance unless required as a direct result of repair or replacement of a defective part under this warranty.

If a problem occurs which the owner believes is covered by this warranty, the owner shall contact the selling dealer, or other authorized dealer, giving that dealer sufficient information to resolve the matter. The owner shall deliver the motor home to the dealer or manufacturing plant location for warranty service.

DEALER'S OBLIGATIONS

By agreement with the manufacturer, the dealer is obligated to maintain the motor home prior to retail sale, to perform a detailed pre-delivery inspection and to repair or replace any parts necessary to correct defects in material or workmanship.

WHEN THE DEALER DOES NOT RESOLVE THE PROBLEM

If the dealer is unable or unwilling to resolve a problem which the owner is convinced is covered by the warranty, he should contact the manufacturing plant at the address listed below and provide the manufacturer with a description in writing of the problem and attempts made to resolve it.

MANUFACTURING PLANT OBLIGATIONS

Upon receipt of notice of a claim, where the dealer was unable or unwilling to resolve the problem, the manufacturing plant will repair or replace any parts necessary to correct defects in material or workmanship, or will take other appropriate action as may be required.

WHEN THE MANUFACTURING PLANT DOES NOT RESOLVE THE PROBLEM

If the representatives of the manufacturing plant are unable to resolve the problem and the owner is convinced that it is covered by this warranty, the owner should call the toll-free number listed below to describe the problem and the attempts made to resolve it.

WHAT IS NOT COVERED BY THE EXPRESS WARRANTY

THIS WARRANTY DOES NOT COVER:

1. THE AUTOMOTIVE SYSTEM (INCLUDING THE CHASSIS AND DRIVE TRAIN), TIRES AND BATTERIES, WHICH ARE COVERED BY THE SEPARATE WARRANTIES OF THE RESPECTIVE MANUFACTURERS OF THESE COMPONENTS.
2. DEFECTS CAUSED BY OR RELATED TO:
 - A. ABUSE, MISUSE, NEGLIGENCE, OR ACCIDENT;
 - B. FAILURE TO COMPLY WITH INSTRUCTIONS CONTAINED IN THE OWNER'S MANUAL;
 - C. ALTERATION OR MODIFICATION OF THE MOTOR HOME;
 - D. ENVIRONMENTAL CONDITIONS (SALT, HAIL, CHEMICALS IN THE ATMOSPHERE, ETC.)
3. NORMAL DETERIORATION DUE TO WEAR OR EXPOSURE, SUCH AS FADING OF FABRICS OR DRAPES, CARPET WEAR, ETC.
4. NORMAL MAINTENANCE AND SERVICE ITEMS, SUCH AS LIGHT BULBS, FUSES, WIPER BLADES, LUBRICANTS, ETC.
5. MOTOR HOMES ON WHICH THE ODOMETER READING HAS BEEN ALTERED.
6. TRANSPORTATION TO AND FROM DEALER OR MANUFACTURING PLANT LOCATION, LOSS OF TIME, INCONVENIENCE, COMMERCIAL LOSS, LOSS OF USE, TOWING CHARGES, BUS FARES, VEHICLE RENTAL, INCIDENTAL CHARGES SUCH AS TELEPHONE CALLS OR HOTEL BILLS, OR OTHER INCIDENTAL OR CONSEQUENTIAL DAMAGES.

SOME STATES DO NOT ALLOW THE EXCLUSION OR LIMITATION OF INCIDENTAL OR CONSEQUENTIAL DAMAGES, SO THE ABOVE LIMITATION OR EXCLUSION MAY NOT APPLY TO YOU.

THIS WARRANTY GIVES YOU SPECIFIC LEGAL RIGHTS, AND YOU MAY ALSO HAVE OTHER RIGHTS WHICH VARY FROM STATE TO STATE.

THE MANUFACTURER IS NOT RESPONSIBLE FOR ANY UNDERTAKING, REPRESENTATION OR WARRANTY MADE BY ANY DEALER OR OTHER PERSON BEYOND THOSE EXPRESSLY SET FORTH IN THIS WARRANTY.

Brand Name: _____ Model: _____ Serial No. _____

FOR SERVICE ASSISTANCE:

Fleetwood Parts & Service
P.O. Box 5700
Riverside, CA 92507
(800) 822-8216

Fleetwood Parts & Service
P.O. Box 1007
Decatur, IN 46733
(800) 822-8216

Fleetwood Parts & Service
P.O. Box 106
Paxinos, PA 17860
(800) 822-8216

CORPORATE HEADQUARTERS:

Motor Home Division
Fleetwood Enterprises, Inc.
P.O. Box 7638
Riverside, CA 92513-7638
(800) 822-8216

This page intentionally left blank

IMPORTANT NOTICE

Our forest product suppliers have advised that urea-formaldehyde is used in the production of particle board, hardwood plywood or paneling which they supply us and which we utilize in our finished product. These suppliers have requested that we communicate this to our customers.

For your information, we are reproducing samples of statements which have been provided to us by our suppliers.

WARNING: THIS PRODUCT IS MANUFACTURED WITH UREA-FORMALDEHYDE RESIN. FORMALDEHYDE VAPOR MAY IN SOME PEOPLE CAUSE HEADACHES, EYE, NOSE AND THROAT IRRITATION, AND AGGRAVATION OF ALLERGIES AND RESPIRATORY PROBLEMS, SUCH AS ASTHMA. PROPER VENTILATION SHOULD REDUCE THE RISK OF SUCH PROBLEMS.

Champion International Corporation

WARNING: IRRITANT: THIS PRODUCT CONTAINS A UREA-FORMALDEHYDE RESIN AND MAY RELEASE FORMALDEHYDE VAPORS IN LOW CONCENTRATIONS. FORMALDEHYDE CAN BE IRRITATING TO THE EYES AND UPPER RESPIRATORY SYSTEM OF ESPECIALLY SUSCEPTIBLE PERSONS SUCH AS THOSE WITH ALLERGIES OR RESPIRATORY AILMENTS. USE WITH ADEQUATE VENTILATION. IF SYMPTOMS DEVELOP, CONSULT YOUR PHYSICIAN.

Georgia-Pacific Corporation

WARNING: THIS PRODUCT IS MANUFACTURED WITH A UREA-FORMALDEHYDE RESIN AND WILL RELEASE SMALL QUANTITIES OF FORMALDEHYDE. FORMALDEHYDE LEVELS IN THE INDOOR AIR CAN CAUSE TEMPORARY EYE AND RESPIRATORY IRRITATION, AND MAY AGGRAVATE RESPIRATORY CONDITIONS OR ALLERGIES. VENTILATION WILL REDUCE INDOOR FORMALDEHYDE LEVELS.

Weyerhaeuser Company

Ventilation is important in maintaining a comfortable environment and we direct your attention to the discussion of ventilation contained in your Owner's Manual.

SAFETY REGULATIONS REGARDING LP GAS SYSTEMS AND LP GAS APPLIANCES

The manufacturer of this recreational vehicle is required to furnish the following consumer information as provided by the National Fire Protection Association and the American National Standards Institute. The information and warnings found here may also be found in other chapters of this Owner's Manual. Please see chapters titled "LP GAS SYSTEM" and "APPLIANCES" for other safety and operating information.

WARNING

LP GAS CONTAINERS SHALL NOT BE PLACED OR STORED INSIDE THE VEHICLE. LP GAS CONTAINERS ARE EQUIPPED WITH SAFETY DEVICES WHICH RELIEVE EXCESSIVE PRESSURE BY DISCHARGING GAS TO THE ATMOSPHERE.

WARNING

IT IS NOT SAFE TO USE COOKING APPLIANCES FOR COMFORT HEATING. COOKING APPLIANCES NEED FRESH AIR FOR SAFE OPERATION. BEFORE OPERATION:

1. OPEN OVERHEAD VENT OR TURN ON EXHAUST FAN, AND
2. OPEN WINDOW.

THIS WARNING LABEL HAS BEEN LOCATED IN THE COOKING AREA TO REMIND YOU TO PROVIDE AN ADEQUATE SUPPLY OF FRESH AIR FOR COMBUSTION. UNLIKE HOMES, THE AMOUNT OF OXYGEN SUPPLY IS LIMITED DUE TO THE SIZE OF THE RECREATIONAL VEHICLE, AND PROPER VENTILATION WHEN USING THE COOKING APPLIANCE(S) WILL AVOID DANGERS OF ASPHYXIATION. IT IS ESPECIALLY IMPORTANT THAT COOKING APPLIANCES NOT BE USED FOR COMFORT HEATING AS THE DANGER OF ASPHYXIATION IS GREATER WHEN THE APPLIANCE IS USED FOR LONG PERIODS OF TIME.

WARNING

PORTABLE FUEL-BURNING EQUIPMENT, INCLUDING WOOD AND CHARCOAL GRILLS AND STOVES, SHALL NOT BE USED INSIDE THIS RECREATIONAL VEHICLE. THE USE OF THIS EQUIPMENT INSIDE THE RECREATIONAL VEHICLE MAY CAUSE FIRES OR ASPHYXIATION.

WARNING

DO NOT BRING OR STORE LP GAS CONTAINERS, GASOLINE, OR OTHER FLAMMABLE LIQUIDS INSIDE THE VEHICLE BECAUSE A FIRE OR EXPLOSION MAY RESULT.

A warning label has been located near the LP gas container. This label reads: DO NOT FILL CONTAINER(S) TO MORE THAN 80 PERCENT OF CAPACITY.

Overfilling the LP gas container can result in uncontrolled gas flow which can cause fire or explosion. A properly filled container will contain approximately 80 percent of its volume as liquid LP gas.

The following label has been placed in the vehicle near the range:

IF YOU SMELL GAS:

1. Extinguish any open flames, pilot lights and all smoking materials.
2. Do not touch electrical switches.
3. Shut off the gas supply at the tank valve(s) or gas supply connection.
4. Open doors and other ventilating openings.
5. Leave the area until odor clears.
6. Have the gas system checked and leakage source corrected before using again.

LP gas regulators must always be installed with the diaphragm vent facing downward. Regulators that are not in compartments have been equipped with a protective cover. Make sure that regulator vent faces downward and the cover is kept in place to minimize vent blockage which could result in excessive gas pressure causing fire or explosion.

TABLE OF CONTENTS

WARRANTY

NOTICES AND WARNINGS

Introduction	1
Warranties	1
Warranty Service	2
Reporting Safety Defects	2
Owner's Information Package	2
Chassis And Vehicle Identification	3
Southwind Body Configurations	3
Conolam® Sidewalls	3
On The Road	7
Motor Home Loading	7
<i>Responsibility for Proper Loading</i>	7
<i>A Few Definitions First</i>	7
Towing a Vehicle or Trailer	7
<i>Carrying Capacity and Load Distribution</i>	8
<i>How To Weigh Your Loaded Motor Home</i> <i>Without A Trailer or Other Towed Load</i>	9
<i>How To Weigh Your Loaded Motor Home</i> <i>With A Trailer or Other Towed Load</i>	9
<i>Loading Tips</i>	10
<i>Tires</i>	10
<i>Tire Inflation</i>	10
<i>Tire Replacement</i>	11
<i>If You Get a Flat Tire</i>	11
<i>Changing a Flat Tire</i>	11
Towing a Vehicle	12
Seats and Seat Belts	12
<i>Combination Lap and Shoulder Belts</i>	13
<i>Safety Belt Maintenance</i>	13
<i>Safety Restraints for Children</i>	13
<i>Safety Belts for Children</i>	13
<i>Safety Seats for Children</i>	13
Driving, Parking, and Mirrors	14
<i>Rear View Video Monitor</i>	14
<i>Body Undercoating</i>	15
<i>Fuel and Fuel Systems</i>	15
<i>Fuel Fill</i>	15
<i>Fuel Types And Vapor Lock</i>	15
General Chassis Topics	15
<i>Variable Speed Engine Fan</i>	15
<i>Engine Temperature Gauges</i>	16
<i>Exhaust System Heat</i>	16
Electronic Transmission Control	16
Carbon Monoxide Safety Precautions	16
Carbon Monoxide Detector	17
Emergency Towing	17

Living With Your Motor Home	19
Hydraulic Leveling System	19
Power Entry Steps	19
Entry Doors and Screens	19
Windows	19
<i>Emergency Exit Window</i>	19
<i>Side Slider Windows</i>	20
Sun Visors	20
Window Shades	20
Storage	20
<i>Exterior Compartments</i>	20
<i>Interior Storage</i>	21
Interior and Furnishings	21
<i>Folding Doors/Privacy Curtain Dividers</i>	21
<i>Interior Lighting — 12 Volt</i>	21
<i>Interior Lighting — 120 Volt</i>	21
<i>Overhead Vents</i>	21
<i>Folding Chairs</i>	22
Monitor Panel	22
<i>Effects of Long-Term Occupancy</i>	22
<i>Ventilation And Controlling Condensation</i>	22
Fire Safety	23
<i>Fire Safety Precautions</i>	23
<i>Smoke Detector</i>	24
Plumbing Systems	27
Fresh Water System	27
<i>City Water Connection</i>	27
<i>Filling The Water Tank</i>	27
<i>Water Pump</i>	28
<i>Water Filter</i>	28
<i>Troubleshooting The Fresh Water System</i>	28
<i>Leaks</i>	28
<i>Sanitizing The Fresh Water System</i>	29
<i>Exterior Shower</i>	29
<i>Water Filter System</i>	29
Waste Water System	29
<i>Toilet</i>	29
<i>Draining The Holding Tanks</i>	29
<i>Holding Tank Care</i>	31
Electrical Systems	33
Chassis Electrical System	33
<i>Chassis Bulbs And Fuses</i>	33
12-Volt Coach System	33
<i>Battery Disconnect</i>	33
<i>Battery Inspection And Care</i>	33
<i>Battery Charging</i>	34
<i>Selecting A Replacement Battery</i>	34

TABLE OF CONTENTS

120-Volt System	34	Miscellaneous Appliances	47
<i>Power Converter</i>	34	<i>Washer/Dryer Drain Screen</i>	47
<i>Ground Fault Interrupter</i>	34	Maintenance	49
Electronic Climate Control System	35	Exterior	49
Solar Panel	35	<i>Stains</i>	49
Coach Fuses and Circuit Breakers	35	<i>Windows, Doors, Vents & Locks</i>	49
Generator	35	Rubber Roof System	50
<i>Generator Fuel Supply</i>	36	<i>Cleaning</i>	50
<i>Generator Operation</i>	36	<i>Care</i>	50
<i>Generator Operating Safety Precautions</i>	36	<i>Sealant Renewal</i>	50
Electrical System Wiring	37	<i>Door, Window, Roof Component</i> <i>And Molding Resealing</i>	50
LP Gas System	39	Interior	50
LP Gas Safety Precautions	39	<i>Fabrics</i>	50
System Components	40	<i>Cutting Block</i>	51
<i>Hoses</i>	40	<i>Counter Tops</i>	51
<i>LP Gas Regulator</i>	40	<i>Walls And Ceiling Panels</i>	51
Using LP Gas System		<i>Bathtub And Plastic Shower Stall</i>	51
At Low Temperatures	40	<i>Floors And Carpeting</i>	51
Filling LP Gas Tanks	41	<i>Engine Access</i>	51
LP Gas System Leak Checks	41	Conolam® Sidewalls	51
LP Leak Detector	42	Lamps and Bulbs	52
Lighting LP Gas Appliances	42	<i>Interior — 12-volt</i>	52
Appliances	45	<i>Interior — 120-volt</i>	52
Water Heater	45	<i>Exterior</i>	52
Refrigerator	45	Exterior Sealant Recommendations	52
<i>Three Way Automatic Refrigerator</i>	45	Maintenance Checklist	52
<i>Acrylic Refrigerator Door Panels</i>	45	Motor Home Storage	55
Furnace	45	Storage Checklists	55
Range	46	<i>Short-Term Storage</i>	55
Range Exhaust Hood	46	<i>Long-Term Storage</i>	55
Air Conditioner	46	Winterization	56
Entertainment Equipment	46	<i>Water System Winterizing</i>	56
<i>120-volt VCR</i>	46	Reactivating the Motor Home After Storage	57
<i>120/12-volt Television</i>	46	Maintenance Chart	61
<i>Video Switcher</i>	47		
TV Antenna	47		
TV and Radio Interference	47		

INTRODUCTION

Welcome to the recreational vehicle life-style and the growing family of motor home owners. We sincerely thank you for choosing a Fleetwood motor home!

Your motor home has been designed to provide you with years of carefree, pleasant traveling and vacationing. Your motor home conforms with, or exceeds, the American National Standards Institute A119.2, CSA Standard Z-240 (units built for Canada), and applicable Federal Motor Vehicle Safety Standards. These standards establish the plumbing, heating, electrical and other requirements for quality and safety. Compliance with ANSI and CSA standards is indicated by the seal attached just outside the entry door.

Like all finely crafted equipment, your motor home will require care and regular maintenance in order to deliver maximum value and performance. The dealer will give you basic operating and maintenance instructions; **however, supplement this by reading all instructional material furnished with the motor home in the Owner's Information Package and Chassis Operator's Manual.** This information outlines important areas of maintenance and provides a maintenance schedule for you to follow for safe, trouble free service from your motor home. Study these instructions carefully before you operate the motor home for the first time. A good working knowledge of your motor home and how to care for it will help you enjoy many miles and years of recreational living.

NOTE: This manual describes many features of your motor home and includes instructions for its safe use. This manual, including photographs and illustrations, is of a general nature only. Some equipment and features described or shown in this manual may be optional. Because of the continuous program of product improvement conducted by Fleetwood, it is possible that recent product changes may not be included. The instructions included in this manual are intended as a guide, and in no way extend the responsibilities of the manufacturing subsidiary, parent company or affiliates beyond the standard written warranty as presented in this manual.

In this manual, statements preceded by the following words are of special significance:

“WARNING” means that there is the possibility of personal injury to yourself and others.

“CAUTION” means that there is the possibility of damage to the vehicle.

“NOTE” indicates points of particular interest for more efficient and convenient operation.

Please pay close attention to these statements while you read this manual.

NOTE: This product is designed for recreational use and short term occupancy only. It is not designed or intended to be used as permanent housing. Use of this product for long term or permanent occupancy may lead to premature deterioration of interior finishes, fabrics, carpeting, drapes, and appliances and fixtures. Damage or deterioration due to long term occupancy is not considered normal, and will under the terms of the warranty constitute misuse, abuse, or neglect, thereby reducing your warranty protection. Before considering this motor home for long term occupancy, consult the relevant sections in this manual.

If you have any questions regarding operation, maintenance, or service, please contact your dealer immediately so he can assist you. Your dealer's Service or Sales Department will handle any normal problems which might occur.

WARRANTIES

Your motor home is covered by one of the most comprehensive warranty programs in the RV industry. Please refer to the warranty in the front of this manual. It explains your rights and obligations, as well as the rights and obligations of the dealer and manufacturer. Please read this section carefully. You will be better informed in case you have a warranty-related problem, and your dealer will be better able to get you on the road again. If you have any questions about the warranty or what it does or does not cover, please contact your dealer.

The materials in your **Owner's Information Package** contain warranty information and operating instructions on the various appliances and components in your motor home. Warranty registration cards for these items should be filled out and mailed as soon as possible after you take delivery of your motor home. If you do not have operating instructions for a particular appliance, contact your dealer.

You will automatically receive an Ownercare Card approximately 3-4 weeks after delivery of your new motor home. This plastic card is imprinted with your name, the motor home serial number, and manufacturing subsidiary location. If your motor home ever needs warranty service, present this card to the dealer.

The motor home has been thoroughly inspected before shipment. Your dealer is responsible for performing a complete predelivery inspection of the chassis and all motor home components as specified in the predelivery checklists supplied by the motor home and chassis manufacturers. **You should receive a copy of these completed checklists from your dealer when your motor home is delivered to you.**

As a part of the predelivery inspection procedure, the dealer is responsible for road testing the motor home, noting and correcting any steering problems before delivery. **FLEETWOOD AND ITS SUBSIDIARIES WILL NOT BE RESPONSIBLE FOR FRONT END ALIGNMENT AFTER THIS PREDELIVERY INSPECTION IS DONE.**

You should return your motor home to the selling dealer for warranty service. If this is not possible, you may contact any other authorized Fleetwood motor home dealer. The service department at any of the locations listed at the back of this manual can help you find a dealer in your area.

If, for some reason, a problem is not handled to your satisfaction:

1. Discuss any warranty-related problems directly with the manager and/or owner of the dealership, giving them an opportunity to help the service department resolve the matter for you.
2. If a problem arises that has not been resolved to your satisfaction by your local dealer, contact the manufacturing subsidiary service center. The locations are listed in this manual. Please contact the one nearest you.
3. We sincerely believe that your dealer and the factory representative will be able to solve any problem which might arise. If their combined efforts are not satisfactory, please send a letter describing the circumstances to:

**Fleetwood Enterprises, Inc.
Motor Home Division - Service
P.O. Box 7638 Riverside, CA 92513-7638**

Please include the brand name and serial number of your motor home. The serial number is located on the identification tag next to the entry door.

4. If you wish to call for assistance, please use this toll-free telephone number:

(800) 322-8216

There may be times when your motor home will need repairs or parts while you are on the road. If your motor home is repaired by a non-authorized repair facility (non-Fleetwood dealer), be sure to save receipts and especially any parts that are replaced. These parts will usually have to be returned to your dealer before you can be reimbursed for their cost.

Warranty Service

If you need service or warranty information, please see the booklets and other documents included in your **Owner's Information Package**. When contacting any of the equipment manufacturers, always have the model and serial numbers available. Appliance identification numbers will be found on tags or plates attached to the appliance.

Chassis component (engine, transmission, axles, etc.) identification numbers will be located in the manuals included with your motor home.

Reporting Safety Defects

If you believe that your vehicle has a defect which could cause a crash or could cause injury or death, you should immediately inform the National Highway Traffic Safety Administration (NHTSA) in addition to notifying Fleetwood Enterprises Consumer Affairs Department.

If NHTSA receives similar complaints, it may open an investigation, and if it finds that a safety defect exists in a group of vehicles, it may order a recall and remedy campaign. However, NHTSA cannot become involved in individual problems between you, your dealer or Fleetwood's manufacturing subsidiary.

To contact NHTSA, you may either call the Auto Safety Hotline toll-free at 1-800-424-9393 (or 366-0123 in Washington, D.C.) or write to:

**NHTSA
U.S. Department of Transportation
Washington, DC 20590.**

You can also obtain other information about motor vehicle safety from the Hotline.

OWNER'S INFORMATION PACKAGE

This package contains important documents about your motor home and its equipment and systems. This Owner's Manual is in the package. Since this manual

does not cover every possible detail of equipment and options installed on or in your motor home, there are booklets and instructional material in the package that will help you safely operate, maintain and troubleshoot those items. Be sure you read all this information and understand the safety and operating instructions included in the package. Additionally, you must follow all maintenance instructions to insure full warranty coverage. If you ever decide to sell or trade your motor home, be sure the new owner gets all the material in this package.

CHASSIS AND VEHICLE IDENTIFICATION

Several numbers are used to identify the vehicle and components used on the vehicle. The V.I.N. or Vehicle Identification Number is the legal identification of the completed vehicle and is the number of the vehicle registration. The V.I.N. is found on the Federal certification tag attached to the interior left sidewall of the motor home driver compartment and left side top of dash. Refer to this information when ordering parts from the chassis manufacturer or chassis dealer service center. The Fleetwood Identification Number (F.I.N.) is located on the tag just outside the main entry door or on the outside left front side of the motor home. Use this number when ordering parts through your Fleetwood dealer or Service Center.

SOUTHWIND BODY CONFIGURATIONS

The Southwind motor home is produced in three different configurations:

- Standard — The body width is approximately 96 inches.
- Wide Body — The body width is approximately 102 inches.
- Widebody Diesel — The body width is approximately 102 inches. The engine is located in the rear in a "pusher" configuration.

Some item or features described in this manual may not apply to all body configurations.

Some states or provinces may restrict the travel of vehicles over 96 inches wide. Contact your travel club or the motor vehicle department of the states or provinces through which you will be traveling for further information.

Widebody motor homes exceed ten feet wide including the exterior mirrors. Keep this in mind when driving. Use caution when maneuvering these vehicles in traffic.

CONOLAM® SIDEWALLS

The sidewalls of this motor home are built with Conolam®. Conolam® is a very dense fiber and polymer material that is strong, light weight and water-resistant. It's high strength permits a thinner wall cross section while providing strength superior to most wood products. See the "MAINTENANCE" chapter of this Owner's Manual for more information.

FEDERAL CERTIFICATION TAG

MANUFACTURED BY: _____
DATE OF MFR: _____

INCOMPLETE VEHICLE MFD. BY: _____
DATE OF INC. VEH. MFR: _____

GROSS VEHICLE WEIGHT RATE: _____

GAWR FRONT	WITH:	RIMS	
	TIRES AT:	PSI COLD	SINGLE

GAWR INTERMEDIATE	WITH:	RIMS	
	TIRES AT:	PSI COLD	SINGLE

GAWR FRONT	WITH:	RIMS	
	TIRES AT:	PSI COLD	SINGLE

This vehicle conforms to all applicable Federal Motor Vehicle Safety Standards in effect in:

VEH. IDENT. NO.: _____

TYPE VEHICLE: MULTI-PURPOSE PASSENGER VEHICLE

The tires on this unit may be different from those shown above. Check tire sidewalls for maximum inflation pressures. Replacement tires must be rated not less than the axle capacity (GAWR).

Located on the left interior sidewall of the motor home driver compartment.

V.I.N. (Vehicle Identification No.)

VEHICLE IDENTIFICATION NUMBER

BAR CODE

Located on the left top of dash

FLEETWOOD.
MOTOR HOMES

OF _____ INC.

PLAN APPROVAL NO. _____

F.I.N. _____

MFD. ID. NO. _____ MODEL _____

DATE OF MFR. MO: _____ YR: _____

Located on the left of the main entry door or on exterior left front side of the motor home.

F.I.N. (Fleetwood Identification No.)

DRIVER'S CONTROLS

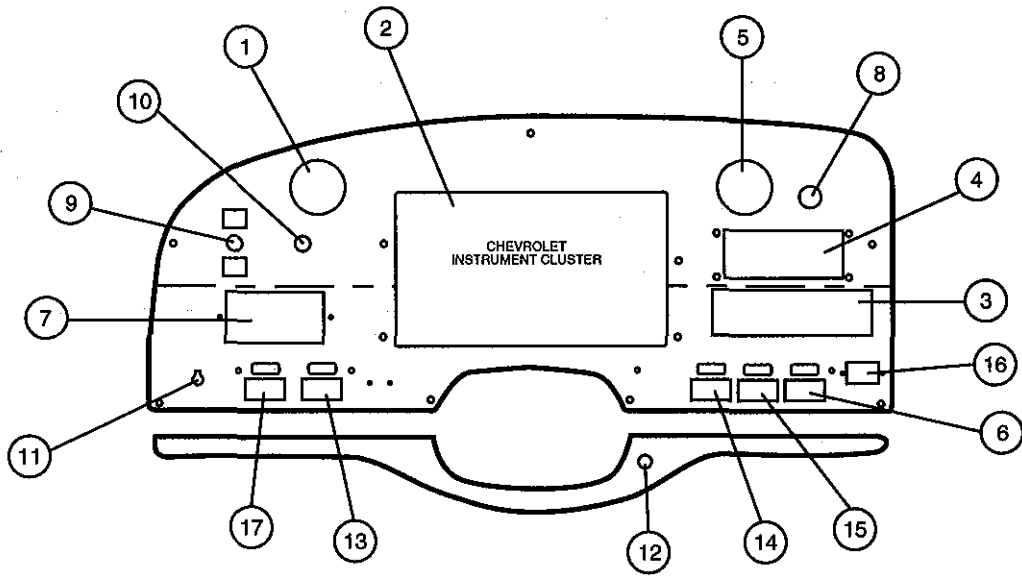

CHEVROLET CHASSIS

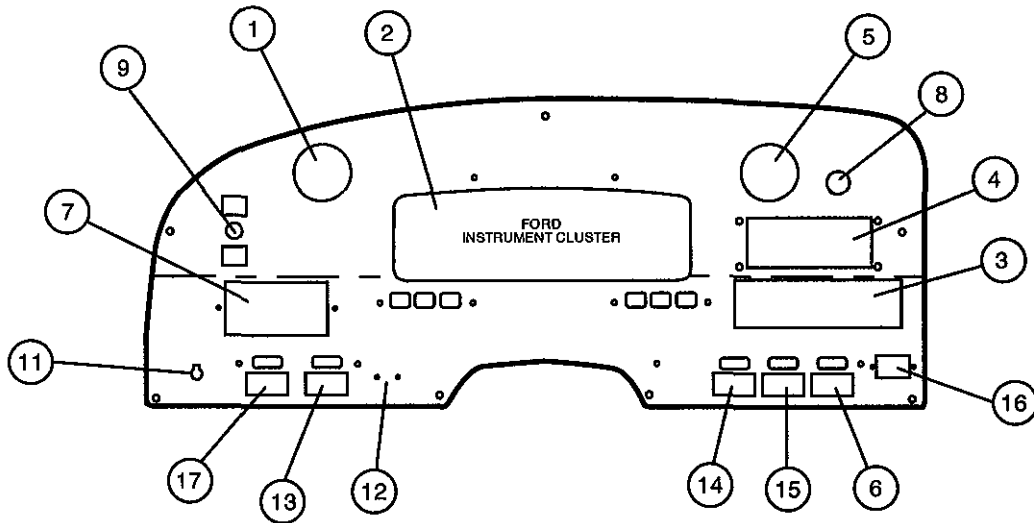

FORD CHASSIS

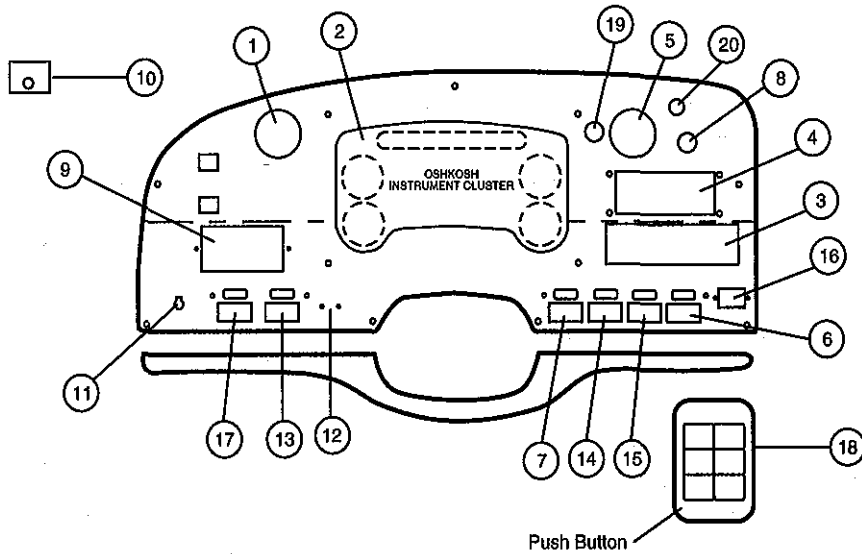

OSHKOSH CHASSIS

1. Heater/Air Conditioning Outlet**2. Instrument Cluster**

Consult chassis operator's manual for details on instruments.

3. Radio/Cassette Player**4. Cab Heater/Air Conditioner Controls**

These controls operate the heating and air conditioning systems for the driver/cockpit area only.

Temperature Control Lever - Used to adjust the temperature of the delivered air. Move lever to the left for cooler, and to the right for warmer.

Fan Speed Switch - Turns fan on and off and adjusts speed.

Air Intake Button (RECIRC) - Selects source of intake air. When the button is pressed in (RECIRC), interior air is recirculated through the system. When button is out, air from outside the vehicle is drawn through the system. Normally, set the button out to circulate fresh air from outside. The RECIRC mode may be used when you desire faster cooling or heating, or if outside air is unusually dusty or odorous.

Air Flow Control Buttons - Selects outlet for the delivered air.

VENT - Air is delivered from the adjustable dash mounted outlets. Vent air will be either heated or cooled depending on position of the temperature lever.

B/L - Bi-level. Air is delivered from both the dash and floor outlets.

FLOOR - Air is delivered from floor outlets, with some directed to the windshield to prevent fogging.

DEF - Air is delivered to the windshield from the top dash outlets. Set fan switch to HI and temperature lever to far right for maximum defrosting.

Air Conditioning On-Off Button - Turns A/C compressor on and off. When air conditioning is desired, press this button in and set fan switch to any position except OFF.

A/C Indicator Light will light when the A/C button is on. In the defrost (DEF) mode, the compressor will automatically be engaged regardless of the button position.

5. Heater/Air Conditioning Outlet**6. Generator Start Switch****7. Leveling Jacks Controls****8. Cigarette Lighter****9. Side Mirror Adjuster****10. "Jacks Down" Light****11. Headlight Switch****12. "Check Engine" Light****13. Auxiliary Start Switch****14. Hood Light Switch****15. Utility Light Switch****16. Generator Hour Meter****17. Fog Light Switch (Optional, selected models)****1. Heater/Air Conditioning Outlet****2. Instrument Cluster**

Consult chassis operator's manual for details on instruments.

3. Radio/Cassette Player**4. Cab Heater/Air Conditioner Controls**

These controls operate the heating and air conditioning systems for the driver/cockpit area only.

Temperature Control Lever - Used to adjust the temperature of the delivered air. Move lever to the left for cooler, and to the right for warmer.

Fan Speed Switch - Turns fan on and off and adjusts speed.

Air Intake Button (RECIRC) - Selects source of intake air. When the button is pressed in (RECIRC), interior air is recirculated through the system. When button is out, air from outside the vehicle is drawn through the system. Normally, set the button out to circulate fresh air from outside. The RECIRC mode may be used when you desire faster cooling or heating, or if outside air is unusually dusty or odorous.

Air Flow Control Buttons - Selects outlet for the delivered air.

VENT - Air is delivered from the adjustable dash mounted outlets. Vent air will be either heated or cooled depending on position of the temperature lever.

B/L - Bi-level. Air is delivered from both the dash and floor outlets.

FLOOR - Air is delivered from floor outlets, with some directed to the windshield to prevent fogging.

DEF - Air is delivered to the windshield from the top dash outlets. Set fan switch to HI and temperature lever to far right for maximum defrosting.

Air Conditioning On-Off Button - Turns A/C compressor on and off. When air conditioning is desired, press this button in and set fan switch to any position except OFF.

A/C Indicator Light will light when the A/C button is on. In the defrost (DEF) mode, the compressor will automatically be engaged regardless of the button position.

5. Heater/Air Conditioning Outlet**6. Generator Start Switch****7. Leveling Jacks Controls****8. Cigarette Lighter****9. Side Mirror Adjuster****11. Headlight Switch****12. Bubble Level (Levelers)****13. Auxiliary Start Switch****14. Hood Light Switch****15. Utility Light Switch****16. Generator Hour Meter****17. Fog Light Switch (Optional, selected models)****1. Heater/Air Conditioning Outlet****2. Instrument Cluster**

Consult chassis operator's manual for details on instruments.

3. Radio/Cassette Player**4. Cab Heater/Air Conditioner Controls**

These controls operate the heating and air conditioning systems for the driver/cockpit area only.

Temperature Control Lever - Used to adjust the temperature of the delivered air. Move lever to the left for cooler, and to the right for warmer.

Fan Speed Switch - Turns fan on and off and adjusts speed.

Air Intake Button (RECIRC) - Selects source of intake air. When the button is pressed in (RECIRC), interior air is recirculated through the system. When button is out, air from outside the vehicle is drawn through the system. Normally, set the button out to circulate fresh air from outside. The RECIRC mode may be used when you desire faster cooling or heating, or if outside air is unusually dusty or odorous.

Air Flow Control Buttons - Selects outlet for the delivered air.

VENT - Air is delivered from the adjustable dash mounted outlets. Vent air will be either heated or cooled depending on position of the temperature lever.

B/L - Bi-level. Air is delivered from both the dash and floor outlets.

FLOOR - Air is delivered from floor outlets, with some directed to the windshield to prevent fogging.

DEF - Air is delivered to the windshield from the top dash outlets. Set fan switch to HI and temperature lever to far right for maximum defrosting.

Air Conditioning On-Off Button - Turns A/C compressor on and off. When air conditioning is desired, press this button in and set fan switch to any position except OFF.

A/C Indicator Light will light when the A/C button is on. In the defrost (DEF) mode, the compressor will automatically be engaged regardless of the button position.

5. Heater/Air Conditioning Outlet**6. Generator Start Switch****7. Diesel Preheat****8. Cigarette Lighter****9. Leveling Jacks Controls****10. Side Mirror Adjuster****11. Headlight Switch****12. Bubble Level (Levelers)****13. Auxiliary Start Switch****14. Hood Light Switch****15. Utility Light Switch****16. Generator Hour Meter****17. Fog Light Switch****18. Shifter****19. Air Pressure Gauge****20. Low Air Warning Indicator**

This page intentionally left blank

ON THE ROAD

MOTOR HOME LOADING

Responsibility for Proper Loading

As the operator of this motor home, you bear the sole responsibility for proper, safe loading. This section will guide you through the steps necessary to properly and safely load your vehicle.

Your motor home chassis is designed to carry a specific maximum weight. This weight includes everything: the weight of the empty motor home itself, all occupants and their belongings, fuel, fresh water, waste water and anything else that may be in or attached to the motor home.

A Few Definitions First

Before discussing loading and weighing, we need to explain some common weight terms. We'll use abbreviations in our discussion. These terms are:

GVWR (Gross Vehicle Weight Rating): This is the maximum allowable load that this motor home was designed to carry. Modifications to your motor home, such as installing bigger tires or changing spring load capacities, will not in any way increase this weight rating. The GVWR is shown on the Federal certification tag posted on the left interior sidewall of the driver's compartment.

GAWR (Gross Axle Weight Rating): This is the maximum allowable weight a specific axle is designed to carry. Each axle has its own GAWR. When you add the GAWRs, they will not necessarily add up to the GVWR. The GAWR is also shown on the Federal certification tag posted on the left interior sidewall of the driver's compartment.

GCWR (Gross Combined Weight Rating): This is the maximum allowable combined weight of the fully equipped and loaded motor home (including passengers, all cargo, fluids, etc.) plus the weight of any fully loaded towed load (such as a trailer, boat, or automobile). The Gross Combined Weight Rating (GCWR) is listed on the wardrobe door tag. Exceeding

the GCWR will cause damage to your motor home drivetrain or chassis, unstable driving and handling characteristics, and will reduce your warranty protection.

GTW (Gross Towed Weight): This is the maximum allowable loaded weight that this motor home has been designed to tow. This cannot be increased by changing the trailer hitch. The GTW is listed on the wardrobe door tag.

MTW (Maximum Tongue Weight): means the maximum vertical load that the towed load applies to the hitch of the motor home. The MTW is listed on the wardrobe door tag.

UVW (Unloaded Vehicle Weight): This is the calculated weight of the motor home, as built at the factory with full fuel, engine oil (and other engine/drivetrain fluids) and LP gas. The UVW does not include cargo, fresh water, passengers, or accessories installed by the dealer. The UVW is listed on the wardrobe door tag.

TOWING A VEHICLE OR TRAILER ("TOWED LOAD")

Note: Some states and provinces require brakes and safety chains on towed vehicles. Consult the proper authorities in the states or provinces through which you will be traveling.

You must consider other important weight factors if you expect to pull a trailer, tow dolly, or another vehicle behind your motor home. These factors have limitations just like the weight factors above. These factors are:

GCWR—Gross Combined Weight Rating

GTW—Gross Towed Weight

MTW—Maximum Tongue Weight

GAWR-Rear—Gross Axle Weight Rating-Rear axles or axles (if equipped with tag axles)

The ratings for these factors are all listed on the wardrobe door tag.

If you expect to pull a vehicle with your motor home, there are additional guidelines that you must follow:

- *Do not use a load equalizing hitch. It could cause structural damage to the motor home frame components.*
- *Limit the tongue weight of the trailer or towing device to the MTW as listed on the ratings tag. Heavier tongue weights can damage your motor home frame and body, cause unstable driving and handling characteristics, and will restrict your coverage under the Ownercare warranty.*
- *Do not tow a vehicle weighing more than the GTW listed on the wardrobe door tag. Heavier towed loads can cause braking problems, damage the motor home structure or drive train, cause unstable driving or handling characteristics, and restrict your coverage under the Ownercare warranty. Changing the trailer hitch will not increase the tow capacity of the motor home.*

The way your motor home handles will be affected by the way the towed unit is loaded. If the tongue weight is too light in relation to the GTW, handling problems can result. Careful load planning and safe experimentation with different loading patterns can help improve motor home handling stability and make your driving and towing experience more enjoyable.

WARNING

DO NOT EXCEED THE RATED LOAD OF THE MOTOR HOME, OR THE RATED LOAD OF ANY AXLE. EXCEEDING THE GVWR, GAWR OR GCWR OF YOUR MOTOR HOME WILL REDUCE YOUR WARRANTY PROTECTION, CAN CAUSE UNDESIRABLE HANDLING CHARACTERISTICS AND MAY CREATE A SAFETY HAZARD.

Carrying Capacity and Load Distribution

The allowable carrying capacity of the motor home is the difference between the GVWR and the weight of the empty motor home. When the motor home is being designed, the number and size of storage compartments, the liquid tank capacities and number of belted seating positions are maximized for value and convenience. If you fill all liquid tanks to capacity, fill all storage compartments and cupboards to maximum volume and fill all available seating positions with passengers, the motor home will be overloaded. The number of passengers and placement of cargo will affect the amount of water and cargo that you can carry (See "Loading Tips").

In addition to knowing the overall weight that can be safely loaded in or attached to the motor home, you must know how to distribute the weight so that correct amounts of weight are placed on the axles. When the load is properly distributed, your motor home will handle better, and you as the driver will be more confident and comfortable.

If your motor home is improperly loaded, driving will be more uncomfortable and much of your driving attention will be given to correcting vehicle wandering, drift, pull and sudden directional changes caused by wind blasts. If the front axle load is below 80-85% of the front axle capacity, these handling discomforts will be more noticeable. Always aim to load your motor home so that the front axle is loaded to at least 80-85% of the front GAWR.

Note: Carrying capacities of your motor home are specified on a label affixed to the inside of a wardrobe door. The label includes all factory installed options. If other equipment such as leveling jacks, awnings, roof pods, etc., are installed after the motor home leaves the factory, the weight of these items must be subtracted from the total of the passenger and cargo carrying capacities.

MOTOR HOME READINGS (from tags)		SCALE READINGS
GVWR _____	MOTOR HOME	Reading 2 _____
Front GAWR _____	FRONT AXLE	Reading 1 _____
Rear GAWR _____	REAR AXLE	Reading 3 _____
Hitch Rating _____	TOWED VEHICLE	Reading 4 _____
GCWR _____	COMBINED VEHICLES	Add 2 and 4 _____

How To Weigh Your Loaded Motor Home Without A Trailer or Other Towed Load

Refer to your local telephone directory to find a public weigh station. The following procedures will help you determine whether your loaded motor home (complete with cargo, fluids, passengers, and driver) is within GAWR, GVWR, and GCWR limits. When you arrive at a weigh station, the attendant will guide you through the correct positioning of the motor home on the scales.

1. Center the front wheels on the scale platform and take a reading. This is the front Gross Axle Weight (Reading 1).

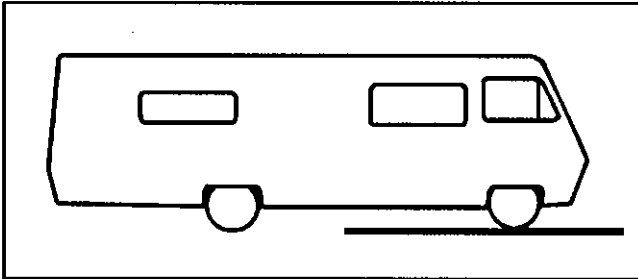

2. Center the entire motor home (all axles) on the scale and take a reading. This is the Gross Vehicle Weight (Reading 2).

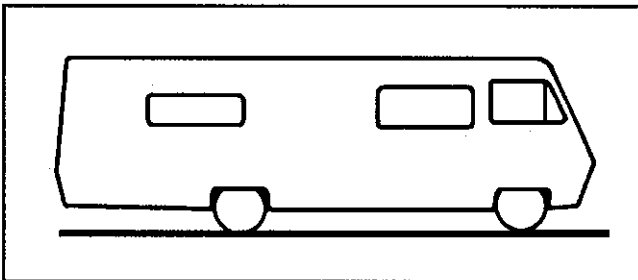

3. Center the rear axle (or both rear axles if your motor home is equipped with tag axles) on the platform and take a reading. This reading is the rear Gross Axle Weight (Reading 3).

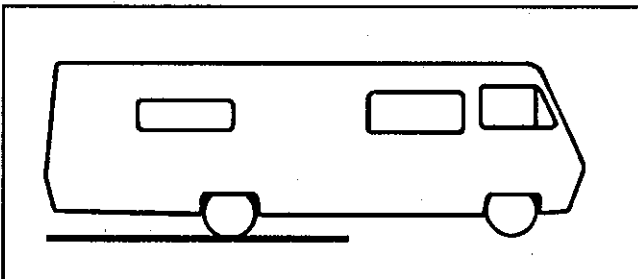

Compare the readings taken on the scales to the weight ratings on the Federal certification tag and wardrobe door tag. Fill in the chart at the back of this manual to aid in comparing weights.

If any readings are higher than the rating, you will have to adjust or remove the load.

How To Weigh Your Loaded Motor Home With A Trailer or Other Towed Load

1. Center the front wheels on the scale platform and take a reading. This is the front Gross Axle Weight (Reading 1).
2. Center the entire motor home so that only the motor home is being weighed. Leave the trailer hitched to the motor home, but resting off of the scale (Reading 2):

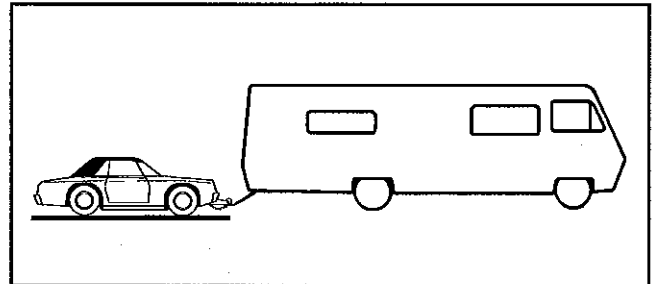

3. Center both the motor home and the trailer combination on the scale and take a reading. This is the Gross Combined Weight (Reading 3).
4. Subtract Reading 1 from Reading 2. This is the rear Gross Axle Weight.

Compare the readings taken on the scales to the weight ratings on the Federal certification tag and wardrobe door tag. Fill in the chart at the back of this manual to aid in comparing weights.

If any readings are higher than the rating, you will have to adjust or remove the load.

If you exceed weight ratings, you will:

- Cause damage to the motor home, drive train, or chassis
- Cause unstable driving and handling characteristics
- Cause unsafe braking
- Reduce your warranty protection.

Since you may load your motor home differently for different trips, loading and weight patterns will change. Periodically reweigh your motor home and log the weights in the back of this manual. Refer to your log as you prepare to load for future trips.

Loading Tips

- Do not load heavy items in upper cabinets.
- Secure and brace items so they wont move during travel, thereby shifting the load.
- Do not load heavy items near either end of the motor home or on the bumpers.
- Adjust cargo storage to keep the side to side wheel loads as equal as possible.
- Fresh water and waste water weigh over pounds per gallon. Carry only as much water as needed for travel use or to balance the load, and whenever possible, empty the holding tanks before traveling.

WARNING

MODIFICATION OF YOUR VEHICLE BY ADDITION OF RACKS NOT ORIGINALLY EQUIPPED BY THE MANUFACTURER TO CARRY ADDITIONAL EQUIPMENT, VEHICLES OR CARGO WILL REDUCE YOUR WARRANTY COVERAGE AND MAY CAUSE PERSONAL INJURY OR PROPERTY DAMAGE.

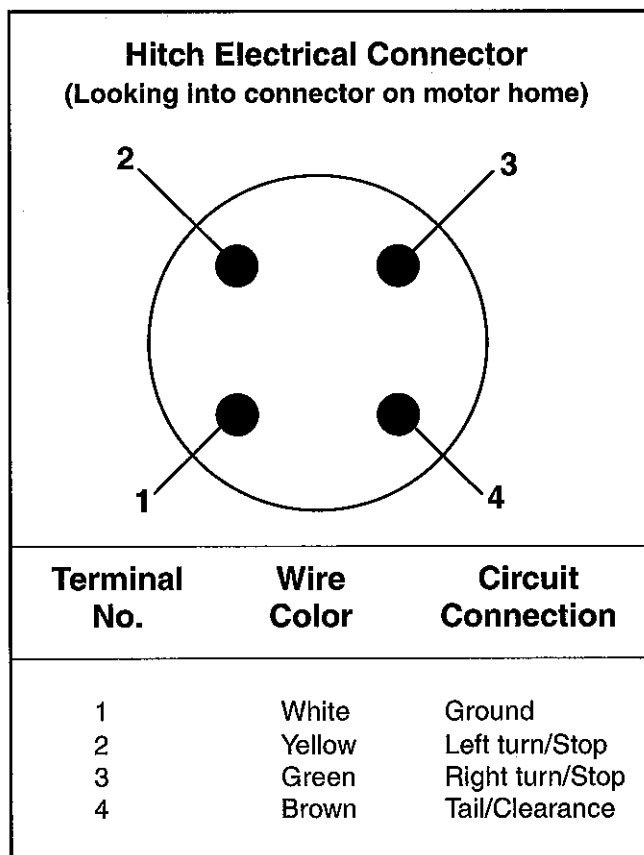

- Make a loading diagram of your properly loaded motor home. This diagram and your loading log will help you locate where specific items are stored, and will help speed the loading process.
- Store emergency items in a readily accessible location. Include a fire extinguisher, tools, first aid kit, rain gear, flashlight, highway warning devices, and an electric cord with light.

WARNING

DO NOT STORE OR CARRY LP GAS CONTAINERS, GASOLINE, OR OTHER FLAMMABLE LIQUIDS INSIDE YOUR MOTOR HOME. THE CONTAINERS MAY LEAK.

Tires

Your motor home is equipped with truck tires. Under normal circumstances and with proper maintenance, you should receive thousands of miles of trouble-free service.

Tire Inflation

For safety and maximum tire life, proper inflation pressure must be maintained. Properly inflated tires also contribute to overall motor home stability and safety. Refer to the tire section in your Chassis Operator's Manual for information on maintenance and tire care.

The proper inflation pressures are stated on the Federal Certification Tag located on the sidewall near the driver's seat

WARNING

FOR SAFETY AND MAXIMUM TIRE LIFE, CHECK TIRE PRESSURES OFTEN (INCLUDING THE SPARE). PAY SPECIAL ATTENTION TO INSIDE REAR DUALS. ALWAYS CHECK PRESSURE WHEN TIRES ARE COLD, AND DO NOT BLEED AIR OUT OF WARM TIRES. FOLLOW THE TIRE PRESSURE INSTRUCTIONS IN THE CHASSIS OPERATOR'S MANUAL.

Note: Check the wheel lug nut tightness periodically. They could work loose during driving. Check the Chassis Operator's Manual for correct lug nut torque and torquing procedure.

Tire Replacement

Replacement tires must be the same size, and have at least the same weight carrying capacity as the original equipment. All tires of the same size and rating may not have the same weight carrying capacity. Consult your tire dealer. The original equipment tires supplied on your motor home have weight carrying capacities to support Gross Axle Weight Ratings (GAWR) as stated on the Federal Certification Tag located on the sidewall near the driver's seat.

If You Get a Flat Tire

In case of sudden tire failure:

- Avoid heavy brake application
- Gradually decrease speed
- Hold the steering wheel firmly and move slowly to a safe, off-road place
- Park on a firm level spot
- Turn off the ignition
- Turn on the hazard flasher system

Changing a Flat Tire

Even with good tire maintenance and normal driving, you may experience a flat tire. Summon professional help through your auto club, travel service, or a local truck service facility. Your motor home is not equipped with a jack or other lifting device. Do not attempt to lift the motor home with a jack. Consult the Chassis Operator's Manual for additional information on tire inflation and proper torque.

WARNING

TO AVOID PERSONAL INJURY AND/OR PROPERTY DAMAGE IF A BLOWOUT OR OTHER TIRE DAMAGE OCCURS, OBTAIN EXPERT TIRE SERVICE HELP. DO NOT ATTEMPT TO CHANGE THE TIRE YOURSELF.

WARNING

TRUCK WHEELS AND TIRES ARE EXTREMELY HEAVY AND MAY WEIGH 100 POUNDS OR MORE. DO NOT ATTEMPT TO REMOVE THE SPARE TIRE UNLESS YOU ARE CAPABLE OF HANDLING THE WEIGHT.

The spare tire is mounted under the rear floor of the motor home. An elevator mechanism allows you to lower the spare tire to ground level.

To lower the tire and wheel assembly:

- Remove safety link located under the spare tire (See diagram).
- Insert the crank handle into the crank receptacle located in the rear right side storage compartment behind a removable plastic plug (the crank handle is also located in this compartment).
- Turn the crank counter clockwise to lower the tire to the ground. Continue turning the crank handle until the chain is slack enough to disengage the tire carrier plate.
- Disengage the carrier plate.
- Slide the tire out from under the motor home.

To store the tire assembly:

- Engage the carrier plate securely through the wheel center hole. Be sure the chain is centered in the wheel center hole.
- Turn the crank clockwise to raise the tire up to the motor home floor. Be sure the tire is snug against the floor.
- Remove and store the crank handle.
- Replace safety link

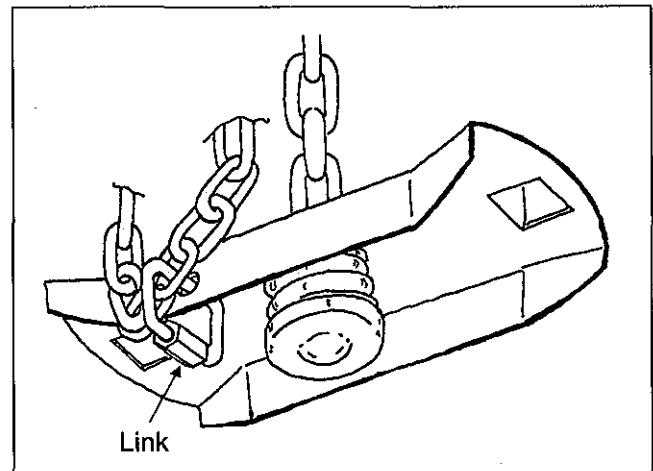

Spare Tire Safety Link Installation

TOWING A VEHICLE

If you expect to pull a vehicle with your motor home, please use these guidelines when choosing a hitch and trailer:

Hitch classification: Class II. Do not use a load equalizing hitch. It could cause structural damage to the frame members.

Limit the tongue weight of trailer or towing device to a maximum of 250 pounds. Heavier tongue weights can damage your motor home frame and body, cause unstable driving and handling characteristics, and will restrict your rights under the Ownercare warranty.

Do not tow a vehicle weighing more than 3500 pounds, or which would result in exceeding the GCWR recommended by the chassis manufacturer. Heavier vehicles can cause braking problems, damage the hitch, the motor home structure or drive train, cause unstable driving or handling characteristics, and/or restrict your rights under warranty. Changing the trailer hitch will not increase the tow capacity of the motor home.

The Gross Combined Weight Rating (GCWR) is listed on the wardrobe door tag. The GCWR is the maximum allowable weight of both the loaded motor home and towed vehicle. Exceeding the GCWR could cause damage to your motor home drivetrain or chassis, unstable driving and handling characteristics, and will reduce your warranty protection.

SEATS AND SEAT BELTS

Seat belts help to restrain you and your passengers in case of a collision. In most states, the law requires their use.

Seat belts provide the best restraint when:

- the seat back is upright
- the occupant is sitting upright (not slouching)
- the lap belt is snug and low on the hips
- the shoulder belt is snug against the chest
- the knees are straight forward

For your safety, your vehicle has combination lap and shoulder belts for the driver and front seat passenger and lap belts without retractors in all other designated seating positions.

WARNING

MAKE SURE THAT YOU AND YOUR PASSENGERS, INCLUDING PREGNANT WOMEN, WEAR SAFETY BELTS. BE SURE THAT LAP BELTS FIT SNUGLY AND AS LOW AS POSSIBLE AROUND THE HIPS. IF SAFETY BELTS ARE NOT USED PROPERLY, THE RISK OF YOU OR YOUR PASSENGERS BEING INJURED IN A COLLISION GREATLY INCREASES.

ALWAYS DRIVE AND RIDE WITH YOUR SEATBACK UPRIGHT AND THE LAP BELT SNUG AND LOW ACROSS THE HIPS TO REDUCE THE RISK OF SERIOUS INJURY TO THE ABDOMEN OR NECK THAT COULD BE CAUSED BY SLIDING UNDER THE SAFETY BELTS IN A COLLISION.

NEVER LET A PASSENGER HOLD A CHILD ON HIS OR HER LAP WHILE THE VEHICLE IS MOVING. THE PASSENGER CANNOT PROTECT THE CHILD FROM INJURY IN A COLLISION.

CHILDREN SHOULD ALWAYS RIDE WITH THE SEATBACK IN THE FULLY UPRIGHT POSITION. WHEN THE SEATBACK IS NOT FULLY UPRIGHT, THERE IS A GREATER RISK THAT THE CHILD WILL SLIDE UNDER THE SAFETY BELT AND BE SERIOUSLY INJURED IN A COLLISION.

NEVER USE A SINGLE BELT FOR MORE THAN ONE PERSON OR ACROSS MORE THAN ONE SEATING POSITION. THIS GREATLY INCREASES THE RISK THAT ONE OR BOTH OF THE PEOPLE WILL BE INJURED IN A COLLISION. EACH DESIGNATED SEATING POSITION IN YOUR VEHICLE HAS A SPECIFIC SAFETY BELT ASSEMBLY WHICH IS MADE UP OF ONE BUCKLE AND ONE TONGUE THAT ARE DESIGNED TO BE USED AS A PAIR.

WARNING

USE THE SHOULDER BELT ON THE OUTSIDE SHOULDER ONLY. NEVER WEAR THE SHOULDER BELT UNDER THE ARM. NEVER SWING IT AROUND THE NECK OVER THE INSIDE SHOULDER. FAILURE TO FOLLOW THESE PRECAUTIONS COULD INCREASE THE RISK AND/OR SEVERITY OF INJURY IN AN ACCIDENT.

Combination Lap and Shoulder Belts

While your vehicle is in motion, the combination lap and shoulder belt adjusts to your movement. However, if you brake hard, corner hard or if your vehicle receives an impact, the lap and shoulder belt locks and prevents you from moving.

To fasten the belt, pull the lap-shoulder belt from the extractor so that the shoulder portion of the belt crosses your shoulder and chest. Insert the belt tongue into the proper buckle until you hear a snap and feel it latch.

To tighten the lap portion of the belt, pull up on the shoulder belt until it fits you snugly. The belt should rest as low on your hips as possible.

Safety Belt Maintenance

Check your safety belt system periodically to make sure that it works properly and isn't damaged. If the webbing shows any wear, nicks or cuts, have it examined by a qualified technician to determine if replacement is necessary. Always have your safety belt system checked after a collision.

Safety Restraints for Children

In most states, you are required by law to use safety restraints for children. If small children (less than four years old, and under 40 pounds) ride in your vehicle, you must put them in safety seats that are made specially for children. Safety belts alone do not provide maximum protection for these children. Check your local and state laws for specific requirements.

WARNING

WHEN USING ANY INFANT OR CHILD RESTRAINT SYSTEM, IT IS IMPORTANT THAT YOU FOLLOW THE INSTRUCTIONS AND WARNINGS PROVIDED BY THE MANUFACTURER CONCERNING ITS INSTALLATION AND USE. FAILURE TO FOLLOW EACH OF THE RESTRAINT MANUFACTURER'S INSTRUCTIONS COULD INCREASE THE RISK OR SEVERITY OF AN INJURY IN THE EVENT OF A COLLISION OR SUDDEN STOP.

SAFETY BELTS AND SEATS CAN BECOME HOT IN A VEHICLE THAT HAS BEEN CLOSED UP IN SUNNY WEATHER, AND COULD BURN A SMALL CHILD. CHECK SEAT COVERS AND BUCKLES BEFORE YOU PLACE A CHILD ANYWHERE NEAR THEM.

WARNING

NEVER LEAVE A CHILD UNATTENDED IN YOUR VEHICLE. ALWAYS REMOVE THE KEY FROM THE IGNITION AND TAKE IT WITH YOU.

Safety Belts for Children

Children who are too large for child safety seats should always wear safety belts.

WARNING

IF SAFETY BELTS ARE NOT PROPERLY WORN AND ADJUSTED AS DESCRIBED, THE RISK OF SERIOUS INJURY TO THE CHILD IN A COLLISION WILL BE MUCH GREATER.

IF THE SHOULDER BELT CANNOT BE PROPERLY POSITIONED SO THAT IT DOES NOT CROSS OR REST IN FRONT OF THE CHILD'S FACE OR NECK, MOVE THE CHILD TO ONE OF THE SEATS WITH A LAP BELT ONLY AND USE THE LAP BELT.

LAP BELTS AND THE LAP PORTION OF LAP AND SHOULDER BELTS SHOULD ALWAYS BE WORN SNUGLY AND BELOW THE HIPS, TOUCHING THE CHILD'S THIGHS.

CHILDREN SHOULD ALWAYS RIDE WITH THE SEATBACK IN THE FULLY UPRIGHT POSITION. WHEN THE SEATBACK IS NOT FULLY UPRIGHT, THERE IS A GREATER RISK THAT THE CHILD WILL SLIDE UNDER THE SAFETY BELT AND BE SERIOUSLY INJURED IN A COLLISION.

Safety Seats for Children

Use a safety seat that is recommended for the size and weight of the child.

WARNING

CAREFULLY FOLLOW ALL OF THE MANUFACTURER'S INSTRUCTIONS THAT COME WITH THE SAFETY SEAT THAT YOU PUT IN YOUR VEHICLE. MAKE SURE THAT THE SHOULDER BELT (IF PROVIDED AT THE SEATING POSITION WHERE THE SAFETY SEAT IS BEING USED) DOES NOT CROSS OR REST IN FRONT OF THE CHILD'S FACE OR NECK. IF YOU DO NOT INSTALL AND USE THE SAFETY SEAT PROPERLY, THE CHILD MAY BE INJURED IN A SUDDEN STOP OR COLLISION.

SEAT BACKS SHOULD BE UPRIGHT FOR USE WITH CHILD SAFETY SEATS.

DRIVING, PARKING, AND MIRRORS

Driving your motor home will be different from driving your family car or truck. Your motor home is large, and you need to be alert to your vehicle's position in traffic. Be cautious when maneuvering to allow for the length and width of the vehicle. Always allow room to corner and to change lanes. Your vehicle's side mirrors will help you keep aware of your vehicle's position and the position of other vehicles and/or obstructions near your motor home. You must monitor them constantly while you are driving. Become familiar with the operation of the side mirrors and learn to use them to view objects and the road beside and behind the motor home.

The rear view mirrors are controlled from a panel located on the driver's door armrest. To adjust the mirrors, select either LEFT or RIGHT mirror and press the appropriate arrow. Activate the mirror heaters by pressing the HEATER position.

Remember that your motor home is heavier than a car, making it less maneuverable and harder to stop. Also, because of its greater side surface area, it is more easily affected by cross winds. Allow extra distances for passing and stopping, and drive at a moderate speed, particularly in traffic and in gusty wind conditions.

Driving on winding or mountain roads is not difficult if done with reasonable care. Observe proper vehicle speeds when ascending or descending hills and always operate in the proper transmission range. Downshift on hills to avoid overheating or undue engine loads. Downshift when descending grades. Engine braking power will help control vehicle speed, and relieve some of the strain on the brakes.

Mountain driving or desert temperatures can put extreme demands on chassis components - especially the transmission. Under extreme use conditions you may need to turn off the vehicle air conditioner to improve engine and transmission cooling.

Be aware of the extra height of your motor home. Check for low hanging tree branches or other obstructions whenever you drive or park. Avoid low overhangs when pulling in for service. Always check overhead clearances of over-passes and bridges. This may be particularly important if you drive with the overhead vents open or if the motor home is equipped with a roof air conditioner, roof rack, CB or TV/ radio antenna. Before leaving on a trip, check your route. Some tunnels prohibit motor homes with LP gas systems.

When parking parallel to a curb, be sure to allow for poles or obstructions as the front and rear portions of the motor home swing wider than an automobile. When parking on an incline, turn the front wheels into the curb in the direction of the roll to aid the parking brake. When parking, always shift the transmission to neutral and set the parking brake.

NOTE: Although your motor home is equipped with power steering, the front wheels may be difficult to turn when at a dead stop. When maneuvering in some close situations, give yourself some room to move either forward or backward. The vehicle has to be in motion for the front wheels to be turned with ease.

WARNING

DO NOT PARK OR IDLE THE MOTOR HOME OVER COMBUSTIBLE MATERIALS SUCH AS TALL GRASS OR DRIED LEAVES. THIS IS PARTICULARLY IMPORTANT IF THE EXHAUST SYSTEM HAS NOT BEEN PROPERLY MAINTAINED. COMBUSTIBLE MATERIALS MAY CATCH FIRE FROM THE HOT EXHAUST GASES, SOOT OR SPARKS THAT COULD ESCAPE THROUGH CORROSION HOLES OR CRACKS.

If operating, parking or idling your vehicle off-road is unavoidable, as is often the case in recreational use:

Be aware that combustible materials could catch fire from the vehicle's hot exhaust system.

Avoid driving your vehicle through or over combustible materials such as leaves, grass, vegetation or stubble high enough to touch, catch or collect on its hot exhaust system.

Parking or idling should be done only in an area where there are no combustible materials under the vehicle.

Rear View Video Monitor

If your motor home is equipped with rear view video monitor, the camera is located at the top rear of the motor home. The rear view picture is displayed on a screen on the motor home instrument panel. The monitor screen may be overlaid with a distance scale reference which gives approximate distance of objects to the rear of the motor home.

To operate the video monitor, the ignition switch must be on and the gear shift in reverse. To override normal operation, the ignition switch must be on and power on at the monitor.

Using the video monitor will take practice. Always allow more space for maneuvering until you are comfortable with the system. Check the side-mounted mirrors often while driving and especially during lane changes and when backing up.

CAUTION

The rear view video monitor system provides a general view of the road and objects to the rear of the motor home. Your perception of this view and the relationships of objects to the motor home and each other will be different from that seen in a rear view mirror. Light conditions and the adjustment of the screen controls will also affect your perception. Always use the side-mounted rear view mirrors with the video monitor system.

The camera lens is exposed to road dirt and will get dirty often. Clean the camera lens and monitor screen with a quality glass cleaner and nonabrasive cloth or towel.

Body Undercoating

In keeping with good engineering practice, and to meet the requirements of chassis manufacturer's, certain chassis and underbody components of your motor home have been coated with an undercoating material. This material is intended to assist in protecting these components from corrosion or other effects of weather and road conditions. Please be aware that certain areas of the motor home do not have undercoating applied.

Fuel and Fuel Systems

See the **Chassis Operator's Manual** in the **Owner's Information Package** for chassis fuel recommendations. The optional generator is designed to run on the same fuel as the chassis. Consult the generator operating instructions for special cautions about maintenance with different types of fuels.

Fuel Fill

The fuel fill is located on the rear of the motor home. Modern fuel systems may build up vapor pressure within the tank as the fuel warms during use or hot weather. Under certain conditions, sudden release of this pressure when removing the fuel cap can cause fuel to spray from the fill opening, creating a fire hazard.

WARNING

WHEN REMOVING THE FUEL CAP, ROTATE SLOWLY ONLY FAR ENOUGH TO ALLOW PRESSURE TO RELEASE. AFTER "HISSING" SOUND STOPS, COMPLETE THE REMOVAL OF THE CAP.

To protect the fuel system from excessive pressure or vacuum, or from sudden release of pressure, replace lost or damaged caps with caps of the same design which are available from your Fleetwood motor home dealer.

Clean up fuel spills immediately. Raw fuel spilled on the motor home could damage the exterior finish, and is a serious fire hazard.

Fuel Types And Vapor Lock

Your motor home's automotive fuel and emissions systems are sophisticated and highly engineered to meet Federal and State emissions standards. They are sometimes sensitive to fuel types and blends, particularly fuels blended for certain altitudes and climates. Fuel suppliers provide customers with the correct fuel for their location and seasonal conditions. Sometimes, though, fuel blended for winter is supplied during summer months.

"Vapor lock" occurs when gasoline vaporizes, and vapor pockets block the flow of liquid fuel to the engine. If you experience engine stall or stutter, you may be experiencing vapor lock. If your engine and fuel system are properly tuned and maintained, you should not experience this problem. If vapor lock occurs, the fuel itself could be the cause. If at all possible, check with the service station operator as to the fuel blend before filling your fuel tank. If you purchase your fuel from nationally recognized fuel dealers, your chances of vapor lock can be reduced. If you store your motor home during the winter months, be aware that when you take the vehicle out of storage in the spring or summer, winter fuel may cause vapor lock until it is consumed.

GENERAL CHASSIS TOPICS

Variable Speed Engine Fan

When the engine is under load or requires maximum cooling, the engine fan adjusts and turns faster. The fan may become very noisy at high speed and when maximum cooling is required. High speed fan noise can sometimes be misinterpreted as transmission slippage. This is not the case. High engine speed and temperature conditions, such as pulling away from a stop after long freeway driving, can cause loud fan noise until the

engine cools down. This fan noise indicates that the fan is doing what it is supposed to do. This noise is not a defect in the fan or the transmission.

Engine Temperature Gauges

Engine temperature gauges have been calibrated to indicate a midrange reading as the "normal" operating temperature. The reason for this is that many owners perceive 212°F as the boiling point. However, this is not the case in an engine with a mixture of glycol and water. As a motor home owner, be aware that the gauge is intended to provide a warning of any rapid change in engine coolant temperature from the "normal" reading of the gauge rather than an absolute temperature reading.

Exhaust System Heat

Your motor home engine has been designed to conform to Federal and State emission requirements. To meet these requirements, engine operating temperatures are high. As a result, the engine and exhaust systems radiate a great deal of heat.

Special heat shields are built into your motor home to protect wiring and other components from possible heat damage caused by the exhaust system. Do not remove these shields, modify the exhaust system, or add additional equipment, such as wiring, plumbing, or other components, which will be affected by exhaust system heat.

ELECTRONIC TRANSMISSION CONTROL

(Diesel-equipped only)

The Allison transmission uses an electronic control unit (ECU). This control unit has a memory module powered by the automotive battery. If the battery is disconnected for over 15 minutes, or if the charge in the battery falls below 7 volts, the ECU memory will be lost. In this case, no damage will be done, but the transmission may shift roughly during a new "learning" period for the memory. After this period, the transmission will shift normally. Refer to the **Allison Operator's Manual** in your **Owner's Information Package**.

CARBON MONOXIDE SAFETY PRECAUTIONS

Carbon monoxide is a colorless, tasteless, odorless gas. It is a by-product of the burning of fossil fuels (gasoline, LP gas, diesel fuel, etc.). The chassis and generator engines, furnaces, water heater, LP gas refrigerator and range produce it constantly while they

are running. **CARBON MONOXIDE IS DEADLY.** Please read and understand the following precautions to protect yourself and others from the effects of carbon monoxide poisoning.

WARNING

EXHAUST GASES ARE DEADLY. DO NOT BLOCK THE TAILPIPES OR EXHAUST PORTS, OR SITUATE THE VEHICLE IN A PLACE WHERE THE EXHAUST GASES HAVE ANY POSSIBILITY OF ACCUMULATING EITHER OUTSIDE, UNDERNEATH, OR INSIDE YOUR VEHICLE OR ANY NEARBY VEHICLES. OUTSIDE AIR MOVEMENTS CAN CARRY EXHAUST GASES INSIDE THE VEHICLE THROUGH WINDOWS OR OTHER OPENINGS REMOTE FROM THE EXHAUST OUTLET. OPERATE THE ENGINES, CARBON MONOXIDE-PRODUCING SYSTEMS OR COMPONENTS ONLY WHEN SAFE DISPERSION OF EXHAUST GASES CAN BE ASSURED, AND MONITOR OUTSIDE CONDITIONS TO BE SURE THAT EXHAUST CONTINUES TO BE DISPERSED SAFELY.

Beware of exhaust gas (carbon monoxide) poisoning symptoms:

Dizziness

Vomiting

Nausea

Muscular Twitching

Intense Headache

Throbbing in Temples

Weakness and Sleepiness

Inability to Think Coherently

If you or others experience any of these symptoms, get out into the fresh air immediately. If symptoms persist, seek medical attention. Shut down the unit and do not operate until it has been inspected and repaired.

WARNING

DO NOT UNDER ANY CIRCUMSTANCES OPERATE ANY ENGINE WHILE SLEEPING.

You would not be able to monitor outside conditions to assure that engine exhaust does not enter the interior, and you would not be alert to exhaust odors or symptoms of carbon monoxide poisoning.

Do not operate an engine with a damaged exhaust system. Check the system frequently for damage. Do not under any circumstances modify the exhaust system(s) in any way.

CARBON MONOXIDE DETECTOR

Your motor home is equipped with a carbon monoxide (CO) detector. It is usually located in the main sleeping area.

If the detector sounds, it is an indication that carbon monoxide gas is present. This may occur while idling in high traffic concentrations were other vehicles as well as your motor home are contributing to the carbon monoxide level in the surrounding air. Sounding of the alarm does not indicate a faulty alarm. The detector is doing its job of warning you of potentially high concentrations of carbon monoxide. See the section on Carbon Monoxide in this manual.

Test the CO detector after the motor home has been in storage, before each trip, and at least once a week during use. Replace the sensor and battery when necessary. Do not replace the battery without replacing the sensor. Sensors are available through your Fleetwood motor home dealer. Please refer to the operating instructions included in your Owner's Information Package.

EMERGENCY TOWING

The only safe and approved towing methods are either an under reach wheel lift device, as installed on a minimum 3-ton tow truck chassis, or a flat bed trailer. Most tow truck operators willing and able to tow motor homes will be familiar with these devices. Be prepared to give the tow truck operator at least the following information when you call:

Length and height of motor home

Chassis manufacturer

Gross vehicle weight rating

CAUTION

Do not tow the motor home from the rear. Towing from the rear will cause serious overloading of the front tires and suspension, possibly resulting in tire or front suspension failure. The rear frame extensions are not designed to withstand the load imposed by lifting from the rear.

The vehicle must be towed from the front, either on the rear wheels (if operational) or on a heavy duty dolly, or transported on a flat bed trailer. Consult your chassis operator's manual.

To prepare your motor home for towing:

1. Secure any loose or protruding parts of the disabled vehicle.
2. Secure any heavy, loose items in the interior.
3. Turn off LP gas appliances and the LP gas tank valve.
4. Do not allow any person to ride in the towed vehicle.

This page intentionally left blank

LIVING WITH YOUR MOTOR HOME

HYDRAULIC LEVELING SYSTEM (IF EQUIPPED)

Controls for the leveling system are located on the instrument panel. A detailed operating and maintenance guide is included in your Owner's Information Package. Read all instructions for this system carefully before operating the system.

WARNING

KEEP PEOPLE CLEAR OF THE MOTOR HOME WHILE THE LEVELING SYSTEM IS OPERATING.

DO NOT USE THE LEVELING JACKS TO RAISE OR SUPPORT THE MOTOR HOME WHEN CHANGING TIRES OR IF YOU WORK UNDER THE MOTOR HOME. BLOCK THE FRAME AND TIRES SECURELY BEFORE WORKING UNDER THE MOTOR HOME, OR CHANGING TIRES. IF THE FRAME AND TIRES ARE NOT PROPERLY BLOCKED, THE MOTOR HOME COULD MOVE WITHOUT WARNING CAUSING SERIOUS INJURY.

DO NOT EXPOSE HANDS OR OTHER PARTS OF THE BODY TO HYDRAULIC LEAKS. HYDRAULIC OIL UNDER HIGH PRESSURE CAN CUT AND PENETRATE THE SKIN CAUSING SERIOUS INJURY.

BEFORE OPERATING THE LEVELING SYSTEM, BE SURE THE MOTOR HOME IS PARKED ON A REASONABLY SOLID SURFACE. IF THE SURFACE IS SOFT, THE LEVELING JACKS MAY SINK INTO THE SURFACE. ON EXTREMELY SOFT SURFACES, PLACE 2' X 2' X 1" WOOD PADS UNDER EACH JACK.

POWER ENTRY STEPS (IF EQUIPPED)

The power entry step is controlled by the ignition switch and by switches on the instrument panel and near the entry step. Power for the entry step is supplied by the coach battery. The battery must be connected for the step to operate as described below. The switches operate the step according to the following table.

IGNITION SWITCH POSITION	STEP SWITCH POSITION	STEP POSITION/ACTION
OFF	ON	Step extends and retracts with the opening and closing of the door.
OFF	OFF	Step is inactive. Will not move regardless of door movement.
ON	ON	Step extends and retracts with opening and closing of door.
ON	OFF	Step is retracted for all door positions. If step is extended when ignition is turned ON, step will retract.

ENTRY DOORS AND SCREENS

The screen door may be separated from the main entry door by depressing the catch or releasing the magnet. A holdback mechanism can be used to secure the main door against the side of the motor home.

WINDOWS

Windows in your motor home are either slider or torque pane type. Slider windows may be locked by turning the lock knob. Torque windows may be opened and adjusted by turning the knob or crank located at the bottom of the window.

Any ventilating window may permit water inside. This water must be trapped and provisions made for draining it to the outside.

On your ventilating windows, water is trapped by the frame. During a heavy downpour, water may be seen in the lower portion of the frame. The sloping sill and weep slots allow the water to drain to the outside. These weep slots must be kept open.

IF WATER COLLECTS IN THE BOTTOM CHANNEL AND OVERFLOWS, check the weep slots for debris and obstructions.

Emergency Exit Window

READ AND UNDERSTAND THESE INSTRUCTIONS BEFORE YOU NEED TO USE THEM. The emergency

exit window provides an emergency means of escape if the motor home doors are blocked or disabled for any reason or in case the motor home must be evacuated under emergency conditions. To release the window, follow the instructions attached to the window frame.

Side Slider Windows

Turn lock, slide window and/or screen to open and close.

NOTE: Screens are not removable for cleaning. They may be pushed out of their frames if the window must be used for emergency exit. In this case, the screens will be destroyed and will probably have to be replaced.

SUN VISORS

The sun visors at the driver and passenger's positions swing down and adjust to provide relief from glare and bright skies. The visors do not adjust to shade the side windows.

Swivel tension may be adjusted with a screwdriver at the tension adjusting screw.

WINDOW SHADES

Window shades or blinds may be fitted to some of your windows.

To raise: Pull the cord straight down until the shade or blind reaches the desired height. Release the cord and the shade will lock in place.

To release and lower the shade: Move the cord toward the center of the shade or blind, pull cord slightly to release lock. Lower as desired. If the shade stops lowering, move the cord to the center of the shade and

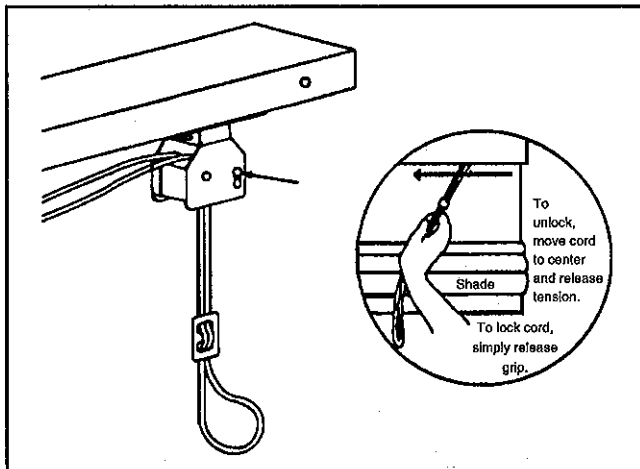

release again.

The shade may occasionally lock in the full up position. To release, grasp the lock mechanism (see illustration) and slide it down. A slight upward pressure on the bottom of the shade may help to relieve tension on cord.

STORAGE

Exterior Compartments

Exterior storage compartments maximize available space and should accommodate most of your storage need. All of the storage compartments, except the LP gas and generator compartments, can be locked. Fire-prevention regulations require that the LP gas and generator compartments be unlocked at all times.

Please note: Your motor home could be overloaded or out of balance if not properly loaded. Refer to the "Motor Home Loading" section of the "ON THE ROAD" chapter of this manual, and follow the loading and weighing instructions in that section. When storing equipment and supplies:

Always keep tools and equipment stored in areas where they will not shift while traveling.

Whenever possible, place heavy articles in storage compartments which are low and in the best location for better weight distribution.

Pack articles carefully in the storage compartments to minimize shifting. If necessary, use straps to prevent movement.

Be sure liquid containers are capped and cannot tip or spill. Secure all glass containers and dishes before traveling.

Exterior storage compartments may not be watertight in all climate conditions. Carry any articles which could be damaged by water inside the motor home.

WARNING

DO NOT STORE FLAMMABLE, VOLATILE LIQUIDS OR HAZARDOUS CHEMICALS INSIDE THE MOTOR HOME OR IN OUTSIDE STORAGE COMPARTMENTS. TOXIC FUMES FROM THESE LIQUIDS OR CHEMICALS MAY ENTER THE INTERIOR OF THE MOTOR HOME.

Interior Storage

The closets and cabinets have friction catches or hidden latches along one edge of the door. Press the latch to open the door. Overhead doors may have supports to hold them open.

Drawers rest in notches when they are closed. To open drawers, lift up slightly, then pull open.

Closets may be equipped with 12-volt lights that may be switched to turn ON when the closet door is opened. Be sure the light goes OFF when the closet door is closed — your battery will be discharged if it stays ON. If the light stays on when the door is closed, the door switch requires adjustment. The same loading considerations apply to interior storage areas as to exterior. Consult the “**Motor Home Loading**” section in the “**ON THE ROAD**” chapter.

INTERIOR AND FURNISHINGS

The materials used inside your motor home have been selected for durability and comfort. With reasonable care, these materials will stand up under years of recreational living. The “**MAINTENANCE**” chapter in this manual outlines care requirements for the various upholstery fabrics, floor, cabinet, and wall finishes.

Dinette Conversion

To convert the dinette into a bed:

- Unfasten** and remove cushions.
- Remove** front dinette seat rail.
- Reach** under the table, either remove leg or fold up under the table top.
- Raise** front portion of table several inches to disengage inserts from the wall supports.
- Lower** table top to the dinette frame to complete bed base.
- Slide** seat and back cushion into place over bed base.

Sofa Conversion

To convert a sofa into a bed:

- Lift** front of sofa frame up and out.
- Push** the back of the sofa back and down.
- Push** the seat belts through the space between the sofa back and seat.

To restore the sofa:

- Pull** the seat belts back up through the space.
- Lift** the front edge of the sofa frame up, and push it back. The sofa back will come up.
- Push** the sofa into position.

Folding Doors/Privacy Curtain Dividers

The dividers allow you to separate areas in the motor home. They glide on nylon rollers and do not require lubrication. They are held closed by a catch. When the dividers are open for traveling, be sure to attach the hold back straps to keep them from sliding back and forth.

Interior Lighting — 12 Volt

Both decorative and “utility” style 12-volt lighting fixtures may be used in your motor home.

Utility style fixtures may be either single or dual. A slide switch selects either single or dual brightness. For your convenience, some lights are operated from wall switches. Clean the lenses with soapy water.

Interior Lighting — 120 Volt

The bathroom and bedrooms are equipped with residential style 120-volt lighting.

The bathroom lights are installed over the medicine cabinets and are switched by a wall-mounted switch

The bedroom table lamps are switched on the lamps. The lamps are secured to the night stands to prevent movement.

Overhead Vents

Overhead vents are located in the galley and bathroom areas for fresh air circulation and exhausting heat, odors and water vapor.

Turn the crank in the center of the vent to open and adjust. Some vents may also be equipped with a 12-volt fan. A switch controls fan operation. Be sure to turn the fan OFF before closing the vent.

Close the vents or lower them before traveling to avoid damage from wind and low overhead clearances.

The vent may be cleaned from the top of the motor home. Use soapy water on the vent cover. The screens may be vacuumed or lightly brushed to remove accumulation of leaves or other debris.

Lubricate the gears and mechanism yearly with a light, water resistant grease.

Folding Chairs

In some models, loose folding chairs are provided for your convenience. The chairs are stored on racks located in an interior rear storage compartment. Loose chairs should be stored when traveling to avoid damage or personal injury.

MONITOR PANEL

The monitor panel allows you to conveniently check the approximate levels in tanks and to check battery condition(s).

Electrical probes installed in the tanks measure the levels at various points in the tanks.

To check tank levels:

Press "LP GAS," "WATER" or "HOLDING TANK "1" or "2" rocker switches. HOLDING TANK 1 is the black water (toilet waste) tank, and HOLDING TANK 2 is gray water (sink and shower wastes).

The "E" or empty indicator light will always be lit when the rocker switches are depressed. If the tank is full, all lights will be on. Lights are sequential, and indicate the level in approximately 1/4 tank increments. If the tank selected is approximately 1/2-full, for example, lights "E," "1/4" and "1/2" will be on.

Erroneous tank level indications can be caused by:

- a. Water with low mineral content. The level is measured by a very low level electrical signal traveling through the liquid. Some water may not conduct the signal properly. This condition may be infrequent, but can exist. Check the panel reading when the fresh water tank is filled.
- b. Material trapped on the sides of the holding tanks may give a full reading when the tank is actually empty.

NOTE: If the sensor probes mounted in the tanks get coated with grease, the monitor panel may indicate falsely or not at all. Avoid pouring grease, oils or similar substances down drains or the toilet. If this is unavoidable, the holding tank(s) should be washed out with a soapy

water solution. See your dealer for additional information.

To check the battery charge:

1. Unplug the 120-volt AC power cord to turn the power converter off.
2. Press "BATTERY" rocker switch on the panel.
3. Turn on a light or any 12-volt appliance. The battery must be checked with a load.
4. Read battery condition on the meter. Red is low, yellow is fair and green is good.

Effects of Long-Term Occupancy

Your motor home was designed primarily for recreational use and short term occupancy. If you intend to occupy the motor home for an extended period, you should understand that the additional wear will cause premature deterioration of structure, interior finishes, fabrics, carpeting, drapes, appliances and fixtures. You should also be prepared to deal with condensation and the humid conditions that may be encountered. The relatively small volume, and tight, compact construction of modern recreational vehicles mean that normal living activities of even a few occupants will lead to rapid saturation of the air, and the appearance of visible moisture, especially in cold weather.

Just as moisture collects on the outside of a glass of cold water during humid weather, moisture can condense on the inside surfaces of your motor home during use in cold weather when humidity of the interior air is high.

Water vapor will condense on the inside of the windows and walls as moisture, or in cold weather as frost or ice. It may also condense out of sight within the walls or the ceiling where it will manifest itself as stained panels. Appearance of these conditions indicates a condensation problem. When you recognize the signs of excessive moisture and condensation, you should take action to minimize their effects.

Ventilation And Controlling Condensation

You can reduce or eliminate interior condensation during cold weather by taking the following steps:

Ventilate with Outside Air

Partially open one or more roof vents and one or more windows to provide controlled circulation of outside air into the interior. While this

ventilation will increase furnace heating load, it will greatly reduce, or eliminate, condensation. Even when it is raining or snowing, outside air will be far drier than interior air and will effectively reduce condensation.

Install Storm Windows

The interior surface of the storm window will be warmer, reducing moisture condensation. **DO NOT COVER THE EMERGENCY EXIT WINDOW.** This window must be left accessible at all times for emergency exit.

Reduce Moisture Released Inside the Motor Home

Run the range vent fan when cooking and the bath vent fan (or open the bath vent) when bathing to carry water vapor out of the motor home. Avoid making steam from excessive boiling or use of hot water. Remove water or snow from shoes before entering to avoid soaking the carpet. Avoid drying overcoats or other clothes inside the motor home.

CAUTION

DO NOT HEAT THE MOTOR HOME INTERIOR WITH THE RANGE OR OVEN. Open flames add moisture to the interior air. Do not use an air humidifier inside the motor home. Water put into the air by the humidifier will increase condensation.

Ventilate Closets and Cabinets

During prolonged use in very cold weather, leave cabinet and closet doors partially open to warm and ventilate the interiors of storage compartments built against exterior walls. The air flow will warm the exterior wall surface, reducing or eliminating condensation and preventing possible ice formation.

Install A Dehumidifier Appliance

During prolonged, continuous use, a dehumidifying appliance may be more comfortable and effective in removing excess moisture from the interior air. While use of a dehumidifier is not a "cure-all", and ventilation, storm windows, and moisture reduction continue to be important, operation of the dehumidifier will reduce the amount of outside air needed for ventilation. Heating load on the furnace will be reduced, and the interior will be less drafty.

FIRE SAFETY

The hazard and possibility of fire exists in all areas of life, and the recreational life-style is no exception. Your motor home is a complex machine made up of many materials - some of them flammable. But like most hazards, the possibility of fire can be minimized, if not totally eliminated, by recognizing the danger and practicing common sense, safety and maintenance habits.

The fire extinguisher furnished with your motor home is rated for Class B (gasoline, grease, flammable liquids) and Class C (electrical) fires since these are the most common types of fires in vehicles. Read the instructions on the fire extinguisher. Know where it is located and how and when to use it.

Remember that portable fire extinguishers are appliances intended for use only by the occupants of a building or area that is threatened by fire. They are most valuable when used immediately on small fires. They have a limited amount of fire-extinguishing material, and therefore must be used properly so this material is not wasted.

Fire extinguishers are pressurized, mechanical devices. They must be handled with care and treated with respect. They must be maintained as outlined in any maintenance instructions provided with the device so they are ready to operate properly and safely. Parts or internal chemicals may deteriorate in time and need replacement. Always follow maintenance and recharging instructions provided by the fire extinguisher manufacturer.

Fire Safety Precautions

Explosive fuel clouds may be present at fuel filling stations.

WARNING

BEFORE REFUELING (EITHER GASOLINE, DIESEL, OR LPG) BE SURE TO TURN OFF ALL PILOT FLAMES AND APPLIANCES IN YOUR MOTOR HOME. TURNING OFF THE PROPANE AT THE TANK IS INSUFFICIENT. PILOTLESS APPLIANCES MAY STILL SPARK OR PILOT FLAMES MAY NOT EXTINGUISH IMMEDIATELY.

WARNING

DO NOT STORE OR CARRY LP GAS CONTAINERS, OR OTHER FLAMMABLE LIQUIDS INSIDE YOUR MOTOR HOME

Instruct occupants on what to do in case of fire, and hold fire drills periodically.

Maintain proper charge in the fire extinguisher.

If you experience a fire while traveling, **MAINTAIN CONTROL OF THE VEHICLE UNTIL YOU CAN SAFELY STOP. EVACUATE THE VEHICLE AS QUICKLY AND SAFELY AS POSSIBLE.**

If you experience a fire while camped, **EVACUATE THE VEHICLE AS QUICKLY AND SAFELY AS POSSIBLE.**

Consider the cause and severity of the fire and risk involved before trying to put it out. If the fire is major or is fuel-fed, move away from the side of the LP gas tank, stand clear of the vehicle and wait for the fire department or other emergency assistance.

If your motor home is damaged by fire, do not drive or live in it until you have had it thoroughly examined and repaired.

Smoke Detector

A battery-powered smoke detector is mounted on the wall in the living/cooking area of your motor home. Please read the smoke detector operating instructions for details on testing and caring for this important safety device.

Test the smoke detector after the motor home has been in storage, before each trip, and at least once a week during use.

The smoke detector should never be disabled due to nuisance or false alarm from cooking smoke, a dusty furnace, etc. Ventilate your motor home with fresh air and the alarm will shut off. **DO NOT DISCONNECT THE BATTERY.**

Replace the battery once a year or immediately when the low battery "beep" signal sounds.

If the smoke detector fails to operate with new batteries, replace it with a new unit, available through an authorized Fleetwood Service Center.

WARNING URETHANE FOAM IS FLAMMABLE!

DO NOT EXPOSE URETHANE FOAMS TO OPEN FLAMES OR ANY OTHER DIRECT OR INDIRECT HIGH TEMPERATURE SOURCES OF IGNITION SUCH AS BURNING OPERATIONS, WELDING, BURNING CIGARETTES, SPACE HEATERS OR UNPROTECTED ELECTRIC LIGHT BULBS.

ONCE IGNITED, URETHANE FOAMS WILL BURN RAPIDLY, RELEASING GREAT HEAT AND CONSUMING OXYGEN AT A HIGH RATE. IN AN ENCLOSED SPACE THE RESULTING DEFICIENCY OF OXYGEN WILL PRESENT A DANGER OF SUFFOCATION TO THE OCCUPANTS. HAZARDOUS GASES RELEASED BY THE BURNING FOAM CAN BE INCAPACITATING OR FATAL TO HUMAN BEINGS IF INHALED IN SUFFICIENT QUANTITIES.

This page intentionally left blank

This page intentionally left blank

PLUMBING SYSTEMS

The plumbing systems in your motor home are constructed of thermoplastic materials. Holding tanks and piping components are strong, lightweight, and corrosion resistant.

Adjustable heat outlets are located in the water compartment and the holding tank compartment. Heat flow can be directed as desired. Please note that in extremely cold weather conditions, these heat outlets will not eliminate the possibility of tank freezing.

FRESH WATER SYSTEM

Fresh water is available from either an external "city water" hookup or on-board storage.

The external system is pressurized by the water system at an RV park or city water supply.

CAUTION

Since water pressures at campgrounds vary, we recommend you install an in-line pressure regulator at the campground water supply faucet. This will protect the motor home water system and your supply hose from excessively high water pressure.

On some models, a manual valve also isolates the on-board fresh water storage tank. This valve can be used to fill the tank from the city water supply.

City Water Connection

Connect the city water system as follows:

Open the protective door over the city water inlet (on some models only).

Connect one end of a potable water hose to park or city water supply. This will usually be a faucet or valve similar to your garden hose valve at home. "Potable water" hoses are available at RV supply stores.

Run the city water supply for a few seconds to clear the line.

Turn OFF the supply.

Connect the hose to the inlet fitting.

Turn ON the supply. Open all faucets and clear the lines. Close faucets.

Disconnect the city water as follows:

Close the park or city water supply valve.

Remove the hose from the city water supply valve.

Disconnect the hose from the inlet, coil and store it.

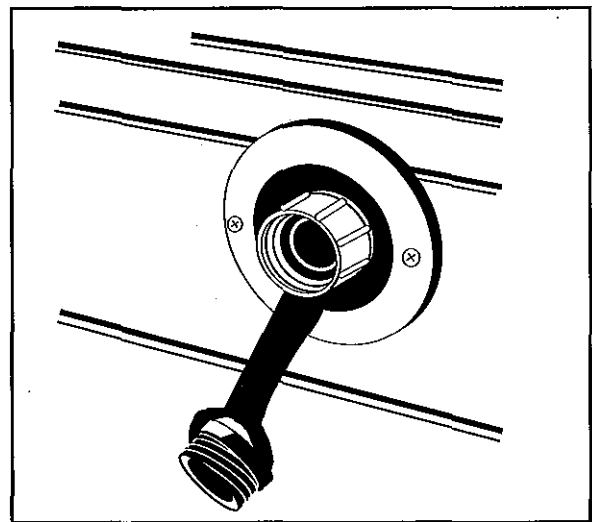

Filling The Water Tank

On some models, you can fill the fresh water tank from the city water connection. Open the tank fill valve and remove the fresh water tank fill cap and vent plug. Monitor the filling of the tank continually. The flow and pressure at some park and city water supplies could damage the tank if left unattended. After filling the tank, close the valve, replace tank fill cap and vent plug.

CAUTION

Overfilling the fresh water tank from a pressurized source will cause serious damage to the water tank or structural components. Monitor water tank filling continually.

The on-board water storage tank may also be filled through a special filler cap outside the motor home. To fill the fresh water tank, open the spout, remove vent plug, and fill the tank using a potable water hose. Check the monitor panel often to determine when the tank is

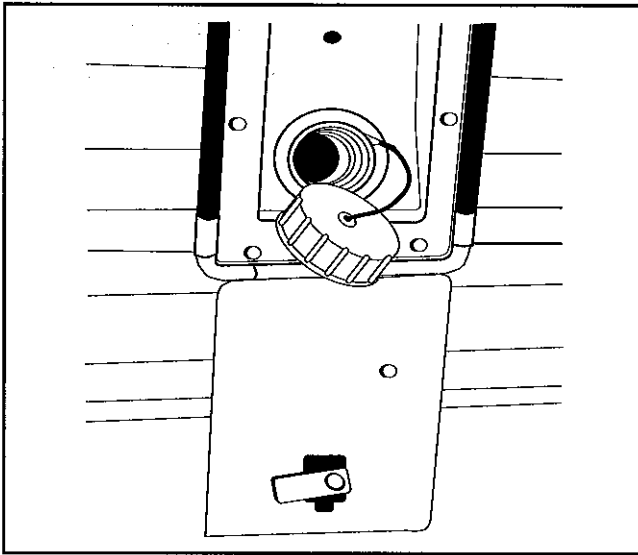

full. If water is flowing from the top vent, your tank is overfilled. Stop filling. After filling the tank, replace vent plug and filler cap.

Avoid leaving water in the tank when the motor home is not in use. Turn the water pump OFF before draining the water tank. Whenever possible, drain the fresh water tank before traveling. Water in the tank will reduce the carrying capacity of the motor home. See “**Motor Home Loading**” section of the “**ON THE ROAD**” chapter.

Water Pump

The on-board fresh water system is pressurized by a self-priming, 12-volt DC pump. The pump operates automatically when the pump power switch is ON and a faucet is opened. When the faucets are closed, the pump shuts off. At free flow, the pump draws approximately 7 to 7-1/2 amps, and can run dry for extended periods without damage. A 20-amp fuse at the converter panel protects the pump circuit. See “**ELECTRICAL SYSTEMS**” chapter.

Turn the pump master switch ON to pressurize the system. When a faucet is opened after the initial filling of the tank, the water may sputter for a few seconds. This is normal and is not cause for concern. The water flow will become steady when all air is bled from the water lines.

Water Filter

Dirt, mineral scale, and organic matter are filtered out of the fresh water system by an in-line water filter on the inlet side of the water pump. If you suspect a clogged filter, it is easily removed and cleaned.

Inspect the filter after using the first full tank of water, clean it, and inspect once a month thereafter.

Loosen the clamp at the inlet end of the filter.

Pull the water line off the filter.

Unscrew the filter from the water pump.

Turn each end of the filter and pull apart.

Flush out and clean screen.

Reverse procedure to install.

Operate the water pump and check for leaks.

Troubleshooting The Fresh Water System

Water system problems usually fall into two categories: inherent system problems, and problems caused by neglect. System problems are usually the result of road vibration and campsite water pressure variations. Problems of neglect usually stem from failure to clean filters, improper winterization, and poor battery maintenance. Most water system problems can be avoided by conscientious maintenance.

Leaks

Vibration, flexing and twisting while traveling can work pipe fittings loose. Check all plumbing for leaks at least once a year. If the water pump runs when a faucet is not open, suspect a leak. Be sure the tank drain valves are tightly closed. Leaks occur most often around threaded fittings. If necessary, tighten or clean and tighten the fittings. Do not overtighten fittings. Connections at galley and lavatory fixtures should not be tightened with a wrench. They will normally seal with hand-tightening. If a leak persists at one of the fittings, disconnect it completely and check for mineral deposits or other foreign matter at the seating surfaces. Clean the surfaces thoroughly and reinstall the fitting.

Connections at the water tank, pump and valves are made with special clamps. They can be replaced with standard aircraft type hose clamps.

Leaks caused by freezing damage can be prevented by proper winterization of the system. See “**STORAGE**” chapter of this manual. Freezing damage is usually extensive and may include a burst water tank, split piping, and a damaged water pump, toilet, and water heater. If you experience this type of damage, repairs can best be made by an authorized Fleetwood dealer.

Sanitizing The Fresh Water System

Sanitize the fresh water tank and piping approximately every three months, and whenever the motor home sits for a prolonged period. This will discourage the growth of bacteria and other organisms that can contaminate the water supply. Use a chlorine/fresh water rinse as follows:

1. Prepare a solution of 1/4-cup household liquid chlorine bleach (5% sodium hypochlorite) to one gallon of water for each 15 gallons of tank capacity.
2. Close drain valves and faucets, pour chlorine solution into the fresh water tank filler spout, and complete filling with fresh water.
3. Turn water pump switch ON. (Be sure you have 12-volt DC power.) Open all faucets individually until water flows steadily, then turn off. This will purge any air from the lines.
4. Top off water tank with fresh water and wait three hours.
5. Drain the entire system by opening all fresh water tank valves, faucets, and plumbing line drain valves.
6. Flush the system with drinking quality water. Let the fresh water flow through the system for several minutes to flush out the chlorine solution.
7. After you stop the flushing, close the tank valve, faucets, and drain valves. You can now fill the tank with fresh water, and the system is ready to use.

Exterior Shower

A shower fixture is located in an exterior compartment on selected models. The water pump must be ON or city water pressure must be available for the shower to operate.

Water Filter System (If equipped)

Water filter systems help provide consistent drinking water quality as you travel. A special filter is part of this system. The filter cartridge is located in the cabinet under the galley sink. Your **Owner's Information**

Package contains detailed operating and maintenance instructions concerning this system.

Please note that the special faucet at the galley is the only outlet for the filtered water. Although filtered water is not available at the standard galley and lavy outlets, the water available at these outlets is filtered by the water pump filter. Note also that this system is not designed for or effective in removing or neutralizing bacterial contaminants.

WASTE WATER SYSTEM

The waste water system in your motor home is made up of sinks, tub, shower, toilet, plumbing drain and vent lines, a "grey water" holding tank, and a "black water" holding tank. Generally, water from the sinks and shower drains into the grey water tank; the toilet drains into the black water tank. The holding tanks make the system completely self-contained and allow you to dispose of waste water at your convenience. A flexible sewer hose is required to connect the holding tank outlet to the inlet of an approved waste water dump station or sewer system.

NOTE: Some floor plans require the shower and/or bathroom sink water to be drained into the black water tank.

The drain plumbing is similar to that used in your home. The system is trapped and vented to prevent waste gases from backing up into the motor home. The drain plumbing is made of ABS plastic, and is durable and resistant to most chemicals.

Toilet

Your motor home is equipped with a marine-type toilet. Please follow the operating instructions found in your **Owner's Information Package**.

Draining The Holding Tanks

The holding tanks terminate in a valve arrangement that permits draining each tank separately or together. The valves are called "knife valves". A blade closes the opening in the sewer drain pipes. The blade is connected to a T-handle that is pulled to release the contents of the tank(s). During self-containment use, the sewer line is securely capped to prevent leakage of

waste material onto the ground or pavement. **DO NOT PULL THE HOLDING TANK KNIFE VALVE OPEN WHEN THE PROTECTIVE CAP IS INSTALLED ON THE PIPE.** Always drain the tank into an acceptable sewer inlet or dump station.

WARNING

HOLDING TANKS ARE ENCLOSED SEWER SYSTEMS AND AS SUCH MUST BE DRAINED INTO AN APPROVED DUMP STATION. BOTH BLACK AND GREY WATER HOLDING TANKS MUST BE DRAINED AND THOROUGHLY RINSED REGULARLY TO PREVENT ACCUMULATION OF HARMFUL OR TOXIC MATERIALS.

Whenever possible, drain the holding tanks before traveling. Waste water and sewage in the holding tanks reduce the carrying capacity of the motor home. See **"Motor Home Loading"** section of the **"LIVING WITH YOUR MOTOR HOME"** chapter.

Drain the holding tanks only when they are at least 3/4 full. If necessary, fill the tanks with water to 3/4 full. This provides sufficient water to allow complete flushing of waste material into the sewer line.

During extended or semi-permanent hookups to sewage systems, waste materials will build up in the tank and cause serious plugging if the tank valves are continuously open. In these cases, keep the valves closed until the tanks are 3/4 full, and then drain into the sewage system.

The holding tank drain valve outlet is to be used with a removable termination fitting that locks onto the outlet with a clockwise twist. Clamp the sewer drain hose to this fitting. A protective cap should remain in place when you are not draining the tanks.

NOTE: LOCAL OR STATE REGULATIONS MAY PROHIBIT HIGHWAY TRAVEL UNLESS THE HOLDING TANK OUTLET IS SECURELY CAPPED.

To drain the holding tanks:

Attach the sewer hose to the holding tank outlet. Insert the end of the hose into the sewer or dump station inlet, pushing it firmly far enough into the opening to be secure. In some cases, adapters may be necessary between the line and the inlet. Arrange the sewer hose so it slopes evenly.

Drain the black water holding tank first. Grasp the handle of the black water knife valve (the large one) firmly and slide the valve open with a quick, steady pull.

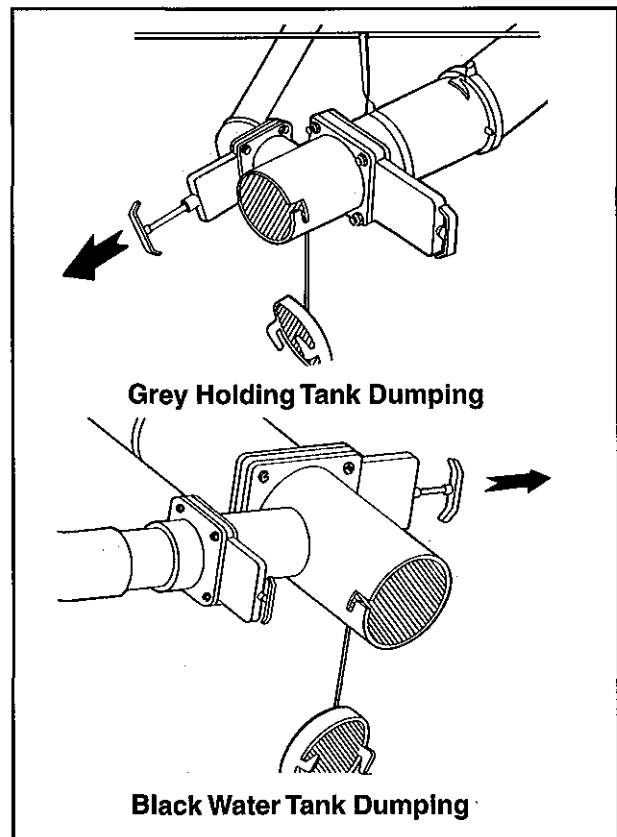

Allow enough time for the tank to drain completely. Rinse and flush the tank through the toilet. When the tank is empty, push the handle in to close the valve. Run enough water into the tank to cover the bottom. This will aid the break up of solid wastes.

To drain the grey water tank, repeat the steps above using the small knife valve. This tank is drained last to aid in flushing the outlets and hose. The grey water knife valve may be left open in a semi-permanent hookup.

Remove the sewer hose and cap the outlet.

Rinse out the sewer hose with fresh water and remove the sewer hose from the dump station.

Replace sewer or dump station covers.

PLEASE...PRACTICE GOOD HOUSEKEEPING WHEN DRAINING WASTES AT A CAMPSITE OR DISPOSAL STATION. LEAVE THE SITE IN GOOD ORDER. ABOVE ALL, DO NOT POLLUTE.

Holding Tank Care

Since holding tanks don't rely on any sophisticated mechanical devices for their operation, they are virtually trouble free. The most common problem is also an unpleasant one — clogging. You can minimize the chances of clogging by keeping the following considerations in mind:

Keep the black water tank knife valve closed. Fill tank to at least 3/4 full before draining. Be sure to cover the tank bottom with water after draining.

Use only toilet tissue formulated for use in septic tank or RV sanitation systems.

Keep both knife valves closed and locked, and the drain cap tightly in place when using the system on the road.

Use only cleaners that are approved for use in septic tank or RV sanitation systems.

Use a special holding tank deodorant chemical approved for septic tank systems in the black water holding tank. These chemicals aid the breakdown of solid wastes and make the system much more pleasant to use.

Do not put facial tissue, paper, ethylene glycol-based or other automotive antifreeze, sanitary napkins or household toilet cleaners in the holding tanks.

Do not put anything solid in either tank that could scratch or puncture the tank.

If the drain system does get clogged:

Use a hand-operated probe to loosen stubborn accumulations. Seriously clogged P-traps may require disassembly. Be careful not to overtighten when reassembling.

Do not use harsh household drain cleaners.

Do not use motorized drain augers.

Sometimes the holding tank valve will get clogged. In this case, a hand-operated auger may be necessary. Be ready to close the valve quickly once the clog is cleared. If the seal gets damaged, it is easily replaced. Replacement seals are available from your dealer.

This page intentionally left blank

ELECTRICAL SYSTEMS

The electrical systems in your motor home are designed and built in accordance with all regulations, codes, and standards in effect at the time the motor home was built.

CHASSIS ELECTRICAL SYSTEM

This is the vehicle electrical system. It includes the vehicle battery, charging system, ignition system, instrument panel and controls, and the headlights, tail-lights, turn signals, and other vehicle lights and accessories.

Chassis Bulbs And Fuses

Replace bulbs with equivalent types as marked on the bulb.

Fuses for the chassis electrical system are located under the instrument panel on the left. Additional fuses may be located under the hood. Others may be found in the 12-volt power leads on the related equipment and accessories.

12-VOLT COACH SYSTEM

All 12-volt lighting fixtures, convenience outlets, 12-volt powered vents, fresh water pump, and 12-volt accessories are included in this system.

The 12-volt power is provided by special deep-cycle, high capacity coach storage battery/ies. Power is also provided by an AC/DC power converter for use when the motor home is plugged into a 120-volt power source. Battery charge is maintained by the motor home engine alternator, or by the converter.

NOTE: All living area radios and tape decks draw from the chassis or coach battery, and extended usage when not traveling may discharge them.

Battery Disconnect

Some accessories or equipment such as clocks, radios, or the refrigerator may draw small amounts of current even when turned "OFF". A relay-operated disconnect system allows you to disconnect either the chassis battery or the coach battery or both. Disconnecting the batteries will help reduce the likelihood of battery discharge over long storage periods.

If you plan to store the motor home for over ten days, press switch/es to OFF. Remember to press switch/es to ON when the motor home is taken out of storage.

WARNING

DO NOT USE THE MOTOR HOME WHEN THE COACH BATTERY IS DISCONNECTED. THE POWER STEP WILL NOT OPERATE AS DESIGNED IF THE COACH BATTERY IS DISCONNECTED.

Battery Inspection And Care

WARNING

DISCONNECT THE 120-VOLT ELECTRIC CORD AND THE NEGATIVE TERMINAL FROM THE COACH BATTERY/IES BEFORE WORKING ON EITHER ELECTRICAL SYSTEM.

WARNING

REMOVE RINGS, METAL WATCHBANDS, AND OTHER METAL JEWELRY BEFORE WORKING AROUND A BATTERY. USE CAUTION WHEN USING METAL TOOLS. IF A TOOL CONTACTS A BATTERY TERMINAL OR METAL CONNECTED TO IT, A SHORT CIRCUIT COULD OCCUR WHICH COULD CAUSE PERSONAL INJURY OR FIRE.

WARNING

DO NOT ALLOW BATTERY ELECTROLYTE TO CONTACT SKIN, EYES, FABRICS, OR PAINTED SURFACES. THE ELECTROLYTE IS A SULFURIC ACID SOLUTION WHICH COULD CAUSE SERIOUS PERSONAL INJURY OR PROPERTY DAMAGE. WEAR EYE PROTECTION WHEN WORKING WITH BATTERIES.

Check the external condition of the battery periodically. Look for cracks in the cover and case. Check the vent plugs and replace if they are cracked or broken. Keep the battery clean. Accumulations of acid film and dirt may permit current to flow between the terminals and discharge the battery.

To clean the battery, wash it with a diluted solution of baking soda and water to neutralize any acid present,

then flush with clean water. Foaming around terminals or on top of the battery is normal acid neutralization. Avoid getting the soda solution in the battery. Be sure the vent caps are tight. Dry the cables and terminals. Don't use grease on the bare metal inside the cable terminals to prevent corrosion. Grease is an insulator. Electricity will not flow through it. A plastic ignition spray will protect the terminals after you have cleaned and reinstalled them.

Check the battery, including water level, often. Keep the carrier and hold down hardware clean and free of corrosion and chemical accumulation.

Battery Charging

Both sets of batteries will be kept charged by the chassis charging system while on the road. The AC/DC power converter will charge the coach battery when plugged into 120-volt service. On those occasions when the battery needs to be charged from a different charging source, please follow these safety guidelines:

Leaving a charger connected to a battery for an extended period of time can shorten battery life.

WARNING

NEVER EXPOSE THE BATTERY TO OPEN FLAME OR ELECTRIC SPARK. CHEMICAL ACTION IN THE BATTERY GENERATES HYDROGEN GAS WHICH IS FLAMMABLE AND EXPLOSIVE. DO NOT ALLOW BATTERY ELECTROLYTE (ACID) TO CONTACT SKIN, EYES, FABRICS, OR PAINTED SURFACES.

Do not smoke near batteries being charged or which have been recently charged. Please note that batteries are being charged while you drive, and while you are connected to 120-volt power through the converter/charger circuit.

Do not break live circuits at the terminals of the battery. Use care when connecting or disconnecting booster leads or cables. These actions, and poor connections, are a common cause of electrical arcs which can cause explosion.

Check and adjust the electrolyte level before charging. Fill each cell to the indicator with distilled water.

Always remove vent caps before charging the battery.

Do not charge the battery at a rate that causes the electrolyte to spew out.

Selecting A Replacement Battery

When the battery requires replacement, always choose a battery with the same physical and electrical characteristics as the original equipment. Your dealer or an authorized Fleetwood Service Center can advise you on proper battery selection.

120-VOLT SYSTEM

This system provides grounded electrical service for appliances such as air conditioners, TV, microwave ovens, etc. The 120-volt system also provides a power source for the converter.

Your motor home is equipped with a heavy duty power cord to connect to an external 120-volt, 30 amp AC service. The cord and connector are molded together to form a weatherproof cable assembly. Do not cut or alter the cable in any way. Do not remove the ground pin in the cable connector, or defeat the ground circuit in the motor home.

WARNING

DO NOT OPERATE THE 120-VOLT ELECTRICAL SYSTEM WITHOUT A PROPER GROUND. ELECTROCUTION OR SEVERE ELECTRICAL SHOCK COULD RESULT.

Power Converter

The converter will automatically supply 12-volt power when your motor home is operating on 120-volt from the generator or a public utility. It will also charge the coach battery.

Ground Fault Interrupter

Bathroom, galley and patio 120-volt electrical outlets are protected by a Ground Fault Interrupter (GFI). This device is intended to protect you against the hazards of electrical shocks possible when using electrical appliances in the bathroom or galley or in damp areas. Should a circuit or appliance (electric shaver, hair dryer, etc.) develop a potential shock hazard, the GFI device is designed to disconnect the outlet (and other outlets on the same circuit), limiting your exposure time.

NOTE: If an outlet doesn't work, check the GFI. Reset it if necessary. If the GFI continues to trip, have the motor home electrical system checked at an authorized Fleetwood Service Center or by a qualified electrician.

Test the GFI at least once a month. To test the GFI, connect to 120-volt AC:

Push the "TEST" button. The "RESET" button should pop out, indicating that the protected circuit has been disconnected.

IF THE 'RESET' BUTTON DOES NOT POP OUT WHEN THE TEST BUTTON IS PUSHED, A LOSS OF GROUND FAULT PROTECTION IS INDICATED. DO NOT USE ANY ELECTRICAL OUTLETS. HAVE THE MOTOR HOME ELECTRICAL SYSTEM CHECKED AT AN AUTHORIZED FLEETWOOD SERVICE CENTER OR BY A QUALIFIED ELECTRICIAN. DO NOT USE THE SYSTEM UNTIL THE PROBLEM HAS BEEN CORRECTED.

To restore power push the "RESET" button.

Your Owner's Information Package contains a card that can be used to record test dates. Keep the card in a conspicuous place and keep it up to date.

ELECTRONIC CLIMATE CONTROL SYSTEM

(Std.—Widebody and Widebody Diesel models; Opt.—Some standard Southwind models)

The dual air conditioners are controlled by the Electronic Climate Control system. This system allows both automatic and manual control of the rooftop air conditioners and the furnace(s) in your motor home.

The system will automatically control the air conditioner temperature, and when in the AUTOMATIC mode, it will control the fan speed to provide the necessary cooling at the quietest fan speed.

The system also monitors the current being drawn by all the electrical appliances in the motor home. Since the air conditioners draw a large amount of current, the climate control system may turn them off to prevent circuit overload. Once the system turns them off, it will keep them off as long as required, and then automatically return them to normal operation.

The system is designed to operate from 120-volt, 30 amp AC service **ONLY**. Connection of the motor home to any other power source will cause *improper* operation of the system. If only 20-amp service is available, current load management must be done manually by the owner and only one air conditioner can be operated at one time.

SOLAR PANEL

(If Installed)

The solar charging panel installed on the roof of your motor home is designed to "trickle-charge" your battery system. It is not intended to be a fast charging or heavy current electrical source. During periods of clear sky and bright sun, the solar panel will help keep your batteries "topped-up". Do not try to operate 12-volt DC appliances with the output of the solar panel. The solar monitor, mounted in the front roof air conditioner shroud, will light up to indicate a trickle-charge.

The panel is expandable with optional expansion panels. Contact your dealer for more information on expansion panels.

COACH FUSES AND CIRCUIT BREAKERS

The 120-volt circuit breakers and 12-volt fuses are located in the same compartment. These devices interrupt the power if the circuit is overloaded.

The 120-volt circuit breakers include a 30 amp main breaker and several smaller breakers for individual circuits. If a circuit breaker is tripped, look for an overload on the circuit, then reset it by turning the breaker OFF and then turning it ON. Do not try to reset a breaker the second time without locating the overload problem.

The 12-volt fuses protect individual circuits. If the circuit is overloaded, it will blow the fuse and the fuse must be replaced. Check the circuit for an overload and replace the fuse with the same type or amperage rating.

WARNING

DO NOT INSTALL 12-VOLT FUSES OR 120-VOLT BREAKERS WITH AMPERAGE RATINGS GREATER THAN THAT SPECIFIED ON THE DEVICE OR LABEL. DOING SO CONSTITUTES A FIRE HAZARD.

GENERATOR

Your motor home may be equipped with a gasoline-powered generator which will provide complete electrical self-containment when regular public utility AC power is unavailable. Controls are at the generator and at a remote control panel located inside the motor home.

With the generator operating, power is available at all of the 120-volt power outlets in the motor home, just as if the cord were connected to an external source. The generator is also connected to the power converter, thus supplying 12-volt power as well.

Generator Fuel Supply

Fuel for the generator is taken from the main fuel tank through a special feeder tube which is higher in the tank than the feeder tube to the motor home engine. This arrangement prevents the generator from running the motor home fuel tank dry.

Your motor home may be equipped with the optional LPG-powered generator. Please refer to the generator operating instructions in your **Owner's Information Package** for more information on operating and maintaining this generator.

Generator Operation

NOTE: Refer to the generator operating instructions provided in your Owner's Information Package for information before starting the generator. Do not start the generator unit with a heavy power load. Always wait at least three minutes after starting generator before turning on (or plugging in) heavy electrical loads, such as the roof air conditioner.

To start the generator, hold the switch in the START position until the unit starts, then release the switch. If the unit is slow to start, DO NOT hold the switch in the START position for more than 10 seconds. Release the switch, wait 15 seconds, then repeat. This will help avoid overheating and damage to the generator starting system. To stop the unit, hold the switch to the STOP position until the engine stops. If you release the switch too soon, the engine will continue to run.

Generator Operating Safety Precautions

Read and understand the generator operating, maintenance and safety instructions furnished in your Owner's Information Package.

Do not smoke or use an open flame near the generator unit or fuel tank.

WARNING

DO NOT PLACE FLAMMABLE MATERIAL OR STORE ANY OTHER MATERIALS IN THE GENERATOR COMPARTMENT.

WARNING

DO NOT BLOCK THE GENERATOR VENTILATING AIR INLETS OR OUTLETS. THE ENGINE REQUIRES A CONSTANT SUPPLY OF COOLING AIR. RESTRICTED VENTILATING AIR INLETS OR OUTLETS CAN CAUSE ENGINE FAILURE OR FIRE FROM ENGINE OVERHEATING.

Do not use generator ventilating air for heating any interior living space. Ventilating air can contain high concentrations of lethal gases.

Check engine fuel lines often. Fuel leakage in or around the compartment is an extreme fire hazard. Do not use the generator until fuel leaks are repaired.

WARNING

EXHAUST GASES ARE DEADLY. INSPECT THE GENERATOR EXHAUST SYSTEM THOROUGHLY BEFORE STARTING THE GENERATOR ENGINE. DO NOT BLOCK THE TAIL PIPE OR SITUATE THE MOTOR HOME IN A PLACE WHERE THE EXHAUST GASES HAVE ANY POSSIBILITY OF ACCUMULATING EITHER OUTSIDE, UNDERNEATH, OR INSIDE YOUR VEHICLE OR ANY NEARBY VEHICLES. OUTSIDE AIR MOVEMENTS CAN CARRY EXHAUST GASES INSIDE THE VEHICLE THROUGH WINDOWS OR OTHER OPENINGS REMOTE FROM THE GENERATOR EXHAUST. OPERATE THE GENERATOR ONLY WHEN SAFE DISPERSION OF EXHAUST GASES CAN BE ASSURED, AND MONITOR OUTSIDE CONDITIONS TO BE SURE THAT EXHAUST GASES CONTINUE TO BE DISPERSED SAFELY.

Be aware of exhaust gas (carbon monoxide) poisoning symptoms. Refer to section on "**Carbon Monoxide Safety Precautions**" in the "**ON THE ROAD**" chapter.

WARNING

DO NOT UNDER ANY CIRCUMSTANCES OPERATE THE GENERATOR WHILE SLEEPING. YOU WOULD NOT BE ABLE TO MONITOR OUTSIDE CONDITIONS TO ASSURE THAT GENERATOR EXHAUST DOES NOT ENTER THE INTERIOR, AND YOU WOULD NOT BE ALERT TO EXHAUST ODORS OR SYMPTOMS OF CARBON MONOXIDE POISONING.

Check the generator exhaust system after every 8 hours of operation and whenever the system may have been damaged, and repair any leaks or obstructions before further operation. Disconnect the battery before performing any maintenance on the generator. Allow the generator to cool before performing any maintenance.

WARNING

DO NOT OPERATE THE GENERATOR WHEN PARKED IN OR NEAR HIGH GRASS OR BRUSH. EXHAUST HEAT MAY CAUSE A FIRE.

WARNING

DO NOT MODIFY THE GENERATOR INSTALLATION OR EXHAUST SYSTEM IN ANYWAY.

DO NOT USE THE GENERATOR AS AN EMERGENCY POWER SOURCE TO A GENERAL RESIDENTIAL OR INDUSTRIAL UTILITY LINE. THIS IS ILLEGAL AND MAY CAUSE SHOCK OR ELECTROCUTION TO POWER LINE UTILITY PERSONNEL ATTEMPTING TO REPAIR POWER LINES.

ELECTRICAL SYSTEM WIRING

Because of the many model, floor plan and option variations available, it is beyond the scope of this manual to include wiring diagrams. In certain situations, specific wiring diagrams may be available to help troubleshoot a problem. If you need specific wiring information, please contact your dealer. Complete wiring diagrams are not available.

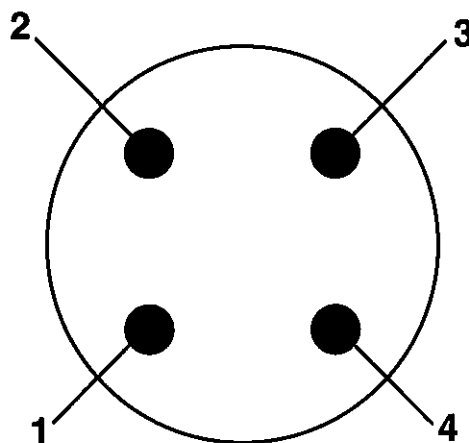

Hitch Electrical Connector
(Looking into connector on motor home)

Terminal No.	Wire Color	Circuit Connection
1	White	Ground
2	Yellow	Left turn/Stop
3	Green	Right turn/Stop
4	Brown	Tail/Clearance

This page intentionally left blank

LP GAS SYSTEM

Liquefied petroleum (LP) gas is available from approved storage tanks to operate your range, oven, furnace and water heater, and as an alternate energy source for some refrigerators. With proper handling precautions, LP gas is safe and provides modern conveniences wherever you travel. The LP gas storage tank is mounted on the motor home chassis. LP gas is stored as a liquid under pressure and vaporizes under the control of a pressure regulator.

A typical LP gas tank installation is illustrated below. Although specific details of the system may differ in your motor home, the major components and their relationships will be similar to those shown.

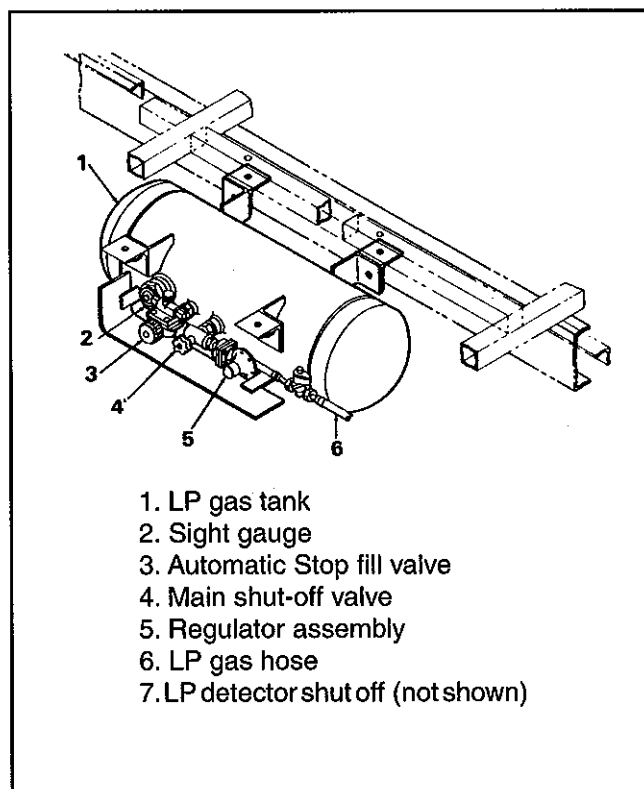

1. LP gas tank
2. Sight gauge
3. Automatic Stop fill valve
4. Main shut-off valve
5. Regulator assembly
6. LP gas hose
7. LP detector shut off (not shown)

LP GAS SAFETY PRECAUTIONS

LP gas is a safe and reliable fuel. As with any other volatile and flammable material, common sense dictates that LP gas be handled and used with respect and caution. Because LP gas systems are so reliable, they are often taken for granted. Neglect can be a very dangerous habit. If the system is maintained regularly, you can expect almost trouble free operation.

WARNING

LP GAS IS FLAMMABLE AND POTENTIALLY EXPLOSIVE. USE PROPER HANDLING, LIGHTING AND VENTILATING PROCEDURES.

1. THE DISTINCTIVE ODOR OF LP GAS INDICATES A LEAK. IF YOU SMELL GAS:

DO NOT TOUCH ELECTRICAL SWITCHES.

EXTINGUISH ALL OPEN FLAMES, PILOT LIGHTS AND ALL SMOKING MATERIALS.

SHUT OFF THE GAS SUPPLY AT THE TANK VALVE(S) OR GAS SUPPLY CONNECTION.

OPEN THE DOOR AND LEAVE THE AREA UNTIL THE ODOR CLEARS.

HAVE THE GAS SYSTEM CHECKED BY A PROFESSIONAL AND THE CAUSE OF THE LEAK CORRECTED BEFORE USING THE MOTOR HOME AGAIN.

2. INSPECT THE ENTIRE LP GAS SYSTEM FOR LEAKS OR DAMAGED PARTS BEFORE EACH TRIP AND BEFORE FILLING TANK. SEE SECTION ON "LP GAS SYSTEM LEAK CHECKS."

3. NEVER CHECK FOR LEAKS WITH AN OPEN FLAME. USE AN APPROVED LEAK DETECTION SOLUTION OR A NON-AMMONIATED, NON-CHLORINATED SOAP SOLUTION ONLY. IF THE LEAK CANNOT BE LOCATED, TAKE THE UNIT TO AN LP GAS SERVICE REPRESENTATIVE.

4. ALWAYS BE CAREFUL WHEN DRILLING HOLES OR FASTENING OBJECTS TO THE MOTOR HOME. THE GAS SUPPLY LINES COULD BE PUNCTURED BY A NAIL OR SCREW.

5. DO NOT RESTRICT ACCESS TO LP TANKS. IN AN EMERGENCY, THE TANK SERVICE VALVE MUST BE EASILY IDENTIFIED AND ACCESSIBLE. THE TANK COMPARTMENT DOOR MUST ALWAYS BE UNLOCKED, AND THE LP LABEL SHOULD BE VISIBLE.

6. DO NOT CARRY OR STORE FILLED OR EMPTY LP GAS CONTAINERS, INCLUDING ACCESSORIES SUCH AS GAS BARBECUES, IN YOUR MOTOR HOME. LP GAS

CONTAINERS ARE EQUIPPED WITH A SAFETY DEVICE THAT RELIEVES EXCESSIVE PRESSURE BY DISCHARGING GAS TO THE ATMOSPHERE. LEAKS CAN OCCUR AT VALVES AND FITTINGS. ALWAYS STORE LP TANKS OUTSIDE WITH THE VALVES CLOSED AND PLUGGED.

7. DO NOT USE ANY LP GAS TANK OTHER THAN THE ONE FURNISHED WITH YOUR MOTOR HOME WITHOUT BEING SURE THAT ALL CONNECTING COMPONENTS ARE COMPATIBLE.

8. TURN OFF LP GAS MAIN VALVE BEFORE FILLING LP GAS TANK OR ENTERING AN LP GAS BULK PLANT OR MOTOR FUEL SERVICE STATION. TURN OFF ALL PILOT LIGHTS AND APPLIANCES INDIVIDUALLY BEFORE REFUELING OF MOTOR FUEL TANKS AND/OR LP GAS CONTAINERS. WHEN NOT INDIVIDUALLY TURNED OFF, AUTOMATIC IGNITION APPLIANCES MAY CONTINUE TO SPARK WHEN LP GAS IS TURNED OFF AT THE CONTAINER.

9. DO NOT FILL LP GAS CONTAINERS TO MORE THAN 80% CAPACITY. OVERFILLING CAN RESULT IN UNCONTROLLED GAS FLOW WHICH CAN CAUSE FIRE AND EXPLOSION. A PROPERLY FILLED CONTAINER HOLDS ABOUT 80% OF ITS VOLUME AS LIQUID.

10. LP GAS REGULATORS MUST ALWAYS BE INSTALLED WITH THE DIAPHRAGM VENT FACING DOWNWARD. MAKE SURE THAT THE REGULATOR VENT FACES DOWNWARD AND THAT THE COVER IS KEPT IN PLACE TO MINIMIZE VENT BLOCKAGE WHICH COULD RESULT IN EXCESSIVE GAS PRESSURE CAUSING FIRE OR EXPLOSION.

11. DO NOT USE A WRENCH OR PLIERS TO CLOSE THE TANK SHUT-OFF VALVE. THIS VALVE IS DESIGNED TO BE CLOSED LEAK-TIGHT BY HAND. IF A TOOL IS REQUIRED TO STOP A LEAK, THE VALVE PROBABLY NEEDS REPAIR OR REPLACEMENT.

12. IF YOU DO NOT HAVE THE SPECIAL TOOLS AND TRAINING NECESSARY, DO NOT ATTEMPT TO REPAIR OR MODIFY LP GAS SYSTEM COMPONENTS.

13. ALWAYS THINK SAFETY.

SYSTEM COMPONENTS

Hoses

The hoses used in your LP gas system meet UL or CSA requirements, and are rated to withstand many times the pressures encountered in the system. Although they are designed for efficient and trouble free use, they can deteriorate from impurities in the air. The average life of LP hoses is two to three years. Consequently, check the hoses for weather checking or other signs of deterioration every time you have the gas tank filled or serviced. When you replace hoses, be sure that replacements are properly rated and approved for RV use.

LP Gas Regulator

The regulator is the heart of the LP gas system. It reduces the tank pressure, which can vary from 250 psi to 7 psi, to a steady 6 ounces (11 inches of water column) to serve the appliances in the motor home. It does this in two stages for safety and efficiency.

Because the regulator is constantly "breathing", it is equipped with a vent. It is very important that the vent stays clean and free from obstruction. Clogging from corrosion, dirt, insect nests or other debris is the most common cause of regulator malfunction. Even a small piece of material that finds its way into the vent can result in improper pressure in the system and possible damage to or failure of components. The regulator is mounted so that the vent is facing downward and is protected from water and dirt by a water-resistant cover. Be sure the cover is on at all times. If the vent becomes clogged, it can be cleaned with a toothbrush. If corrosion is evident, contact a qualified LP gas service technician for a replacement regulator.

WARNING

DO NOT ATTEMPT TO ADJUST THE REGULATOR. IT HAS BEEN PRESET BY THE REGULATOR MANUFACTURER. IF ANY ADJUSTMENT IS REQUIRED, IT MUST BE MADE BY A QUALIFIED LP GAS SERVICE TECHNICIAN USING SPECIAL EQUIPMENT.

USING LP GAS SYSTEM AT LOW TEMPERATURES

Your LP gas system will function at low temperatures, provided the system components are kept at a temperature above the vapor point of the LP gas. Ask your LP gas supplier or your motor home dealer for information on product blends available in your area and the areas in which you will be traveling.

The following chart shows the reduction in available BTU's/hour under various fill levels as the temperature drops:

20 lb. Tank*					
% FULL + 20°	0°	-5°	-10°	-15°	
60%	36,000	18,000	12,750	8,500	4,250
50%	32,400	18,200	12,150	8,100	4,050
40%	28,800	14,400	11,400	7,600	3,800
30%	25,200	12,600	10,450	7,300	3,150
20%	21,600	10,800	8,100	5,400	2,700
10%	16,200	8,100	6,075	4,050	2,025

*30 lb. Tank multiply x 1.40

The chart clearly shows how the availability of the gas is reduced at lower temperatures. With this in mind, keep your LP tank as full as possible during cold weather. Check the BTU/hr rating plates on your LP gas appliances. This information will help you manage your LP gas requirements efficiently.

LP gas systems can and do freeze up in very cold weather. It is a common misconception that the regulator or the gas itself freezes. Actually, it is moisture or water vapor that gets trapped in the system or absorbed by the gas that freezes and causes the problem. This ice can build up and partially or totally block the gas supply.

There are a number of things you can do to prevent freeze up:

1. Be sure the gas tank is totally moisture-free before it is filled. If you are not sure, have an LP service station inject an approved anti-freeze or deicer into the tank.
2. Be sure the tank is not overfilled. This is also a safety consideration.
3. Have the gas tank purged by the LP gas service station if freeze up occurs.
4. Be sure you have the proper gas blend for your traveling area. If you have the proper gas blend, it is very unlikely that the gas is at fault.

If, despite precaution, you do experience freeze up, ask your LP gas supplier to service the tank or regulator as required.

FILLING LP GAS TANKS

To fill the chassis-mounted storage tank, drive the vehicle to an LP gas supplier or a service station which sells LP gas. Do not attempt to fill the tank yourself.

WARNING

TURN OFF LP GAS MAIN VALVE BEFORE FILLING LP GAS TANK OR ENTERING AN LP GAS BULK PLANT OR MOTOR FUEL SERVICE STATION. TURN OFF ALL PILOT LIGHTS AND APPLIANCES INDIVIDUALLY BEFORE REFUELING OF MOTOR FUEL TANKS AND/OR LP GAS CONTAINERS. WHEN NOT INDIVIDUALLY TURNED OFF, AUTOMATIC IGNITION APPLIANCES MAY CONTINUE TO SPARK WHEN LP GAS IS TURNED OFF AT THE CONTAINER.

WARNING

DO NOT FILL LP GAS CONTAINERS TO MORE THAN 80% CAPACITY. OVERFILLING CAN RESULT IN UNCONTROLLED GAS FLOW WHICH CAN CAUSE FIRE AND EXPLOSION. A PROPERLY FILLED CONTAINER HOLDS ABOUT 80% OF ITS VOLUME AS LIQUID.

LP GAS SYSTEM LEAK CHECKS

The smell of LP gas (actually, an additive, ethyl mercaptan) indicates a leak. Obvious leak sources are fittings, valves and couplings.

For your safety, check for leaks in your gas system each time the tank is filled and before each trip. Always check the system any time you detect a garlic-like odor. Listen for a sustained hiss or hum when you turn the gas on. This may indicate a leak.

The first time you have your LP tank filled, have the serviceman bleed a little LP gas out of the small outage valve (this also lets you check that the bottle is not overfilled) and note the odor for future reference. A small number of people cannot smell this odor; if you are one of these you must take extra care in checking for leaks, as well as whenever you use LP gas appliances.

To perform a leak check, swab a mixture of a non-ammoniated, non-chlorinated soap solution or an approved leak detection solution over each fitting, joint and connection in the system. Open the tank service valve. Inspect each joint. If even the smallest bubbles appear at any joint, this joint must be re-made. Refer repairs to an authorized Fleetwood service center or your LP gas service facility. Never attempt to repair gas piping without proper tools and know-how.

Potential trouble spots for leaks are areas where piping runs close to chassis and frame members. Look for chafes and cracks around pipe hangers. If you find

defects in any LP gas system component, have it repaired or replaced before using the system.

As an added precaution, do a visual check of all exposed piping and fittings after you have arrived at a destination and before you use the LP gas system. Travel and road shocks may have caused damage to the system that you will need to repair before using the appliances.

WARNING

NEVER CHECK FOR LEAKS WITH AN OPEN FLAME. DO NOT CHECK FOR LEAKS USING AMMONIATED OR CHLORINATED HOUSEHOLD TYPE DETERGENTS. THESE CAN CAUSE CRACKS TO FORM ON THE METAL TUBING AND BRASS FITTINGS. IF THE LEAK CANNOT BE LOCATED, TAKE THE UNIT TO AN LP GAS SERVICE REPRESENTATIVE.

Keep the tank valve closed and turn off all appliances if the unit is not being used.

WARNING

DO NOT USE PLIERS OR A WRENCH TO TIGHTEN VALVES. IF A VALVE IS NOT LEAK-TIGHT WHEN CLOSED BY HAND, SEE AN LP GAS SERVICE REPRESENTATIVE.

LP LEAK DETECTOR

A permanently installed LP gas leak detector is located near the floor. The unit contains an alarm that will sound alerting you to the presence of low levels of potentially dangerous LP gas that may have been released due to a gas leak. The unit will also disconnect the gas supply at the LP tank when it senses LP or similar gases such as hair spray or cleaning solvent.

The detector unit is powered by the 12-volt DC system in your motor home. A power switch is located on the panel. A green light on the detector front panel indicates that the detector has power. If the power switch is OFF, gas flow from the tank is cut off by a special solenoid valve located at the tank.

Test the leak detector each time the motor home is relocated and set up for use.

Testing Procedure:

Hold a butane-fueled pocket lighter near the sensor.

Open the lighter valve without striking the flame.

The leak detector should respond within a few seconds.

Press the silence button to reset the alarm.

Lightly fan the area around the detector to insure complete dispersion of the gas from the lighter, and to prevent another sounding of the alarm.

A silence button allows you to temporarily quiet the alarm for 60 seconds after it has been set off or after testing.

If the alarm does not sound during a test or if the green indicator light is not visible, see your dealer or an authorized Fleetwood Service Center. There are no batteries or user serviceable parts inside the unit.

NOTE: Remember to turn off the detector if you are not using your motor home. The detector draws enough current to discharge your battery.

LIGHTING LP GAS APPLIANCES

Detailed operating information for the LP gas appliances can be found in your **Owner's Information Package**. Please read and follow these instructions.

Air trapped in the gas lines may delay the initial lighting of any appliance. It could take several seconds or minutes for the gas to reach the appliance. To purge some of the air from the gas system, first light a burner on the range. The other appliances will then light more quickly.

We recommend lighting the pilot light at the range, if equipped, rather than individually lighting each burner. This will help prevent accidental leaks at the burner. Be sure the pilot light is extinguished while traveling.

The first time the furnace or oven is operated, paints and oils used in its manufacture may generate some smoke and fumes. If this occurs, open doors and windows to air out the motor home. These materials should burn off after the first 15 to 20 minutes of appliance operation.

ALWAYS FOLLOW THE APPLIANCE MANUFACTURER'S LIGHTING AND OPERATING INSTRUCTIONS.

This page intentionally left blank

This page intentionally left blank

APPLIANCES

The appliances installed in your motor home are tested by independent laboratories and comply with rigid standards established by these organizations. All appliances are covered by Fleetwood's Ownercare Warranty program. Each appliance is also warranted by its manufacturer.

*NOTE: The individual appliance manuals included in your **Owner's Information Package** contain detailed operating and maintenance instructions. Always refer to the respective manual for the appliance in question.*

WARNING

THE WATER HEATER AND FURNACE COMBUSTION AIR EXHAUST PORTS MAY BE EXTREMELY HOT DURING WATER HEATER AND FURNACE OPERATION. DO NOT TOUCH THESE OUTLETS OR ALLOW ANY MATERIAL TO COME WITHIN CLOSE PROXIMITY OF EXHAUST PORTS WHILE OPERATING THE WATER HEATER AND/OR FURNACE.

WATER HEATER

The water heater operates on LP gas, and is much like the one in your home. It contains an automatic shut off valve which stops the gas supply if the water temperature rises too high. The water heater is reached through an access panel on the outside of the motor home.

CAUTION

DO NOT LIGHT WATER HEATER UNTIL IT IS FILLED WITH WATER.

Turn on the hot water faucet at the galley sink. If water flows continuously the heater is full.

REFRIGERATOR

Consult the operating instructions furnished in your **Owner's Information Package**. Before operating the refrigerator when the motor home is parked, make sure it is level. If it is not level, the refrigerant will not circulate, cooling action will stop, and the refrigeration system may be damaged.

The refrigerator uses the absorption principle of operation. If you plan to cool food or drinks in high outside temperatures, precool the food, and park the motor home with the refrigerator vent door in the shade. Once the interior of the refrigerator is cool, the refrigeration system will usually maintain this temperature. If the inside of the refrigerator is hot, the food is not pre-cooled, and the outside temperature is high, be prepared for longer cooling times.

Three Way Automatic Refrigerator (If Equipped)

Some models may be equipped with a Three-Way Automatic Energy Selector refrigerator. The refrigerator will automatically select the best available energy source for the conditions — 120-volt, 12-volt or LP gas.

The refrigerator will only operate on 12-volt DC power when the motor home engine is running.

If battery power is low, a built-in battery protection feature switches refrigerator operation to LP gas. An indicator lamp on the refrigerator will light. When the battery charge level is normal, the refrigerator automatically returns to the 12-volt operating mode.

Acrylic Refrigerator Door Panels (If Equipped)

Some refrigerator models are equipped with a decorative acrylic door panel. Use a cleaner specially formulated for acrylics and a soft cloth to clean this surface. Do not use harsh or abrasive detergents or cleansers.

FURNACE

The furnace is a forced-air unit fueled by LP gas. All furnaces are equipped with a wall thermostat for individual temperature settings.

The furnace will not operate properly if your stored personal items block the free flow of air at the registers or the return air to the furnace. Storage under cabinets should be done carefully so as to not crush or damage the furnace ducting.

Smoke and fumes created as a result of burning off manufacturing compounds are sometimes present the first time the furnace is used. This is normal; however,

the initial light off should be done with windows and doors open and be of adequate duration to completely burn off the residue.

WARNING

PORTABLE FUEL-BURNING APPLIANCES ARE NOT SAFE FOR HEATING INSIDE THE MOTOR HOME. ASPHYXIATION OR CARBON MONOXIDE POISONING CAN OCCUR.

RANGE

The gas oven and burners are operated with LP gas. The basic operation is the same as the range in your home.

A warning label has been located in the cooking area to remind you to provide an adequate supply of fresh air for combustion. Unlike homes, the amount of oxygen is limited in an RV due to the size and construction of the vehicle. Proper ventilation when using the cooking appliances will prevent the dangers of asphyxiation. Refer to "**Lighting LP Gas Appliances**" section in the "**LP GAS SYSTEM**" chapter of this manual.

WARNING

DO NOT USE OPEN FLAMES TO WARM THE LIVING AREA. GAS COMBUSTION CONSUMES THE OXYGEN INSIDE THE MOTOR HOME.

RANGE EXHAUST HOOD

The exhaust hood allows vapors and cooking odors to escape, and provides a vent for the galley area. Switches for the fan and light are located on the front of the hood. The hood has a grease filter screen which requires periodic cleaning. To clean, remove the screen and wash in soapy water. Rinse with water and let the screen drain dry before replacing it. The fan blades may also be cleaned with soapy water. Replace the light bulb with an equivalent type.

The range hood also houses the monitor panel. Operating instructions for the monitor panel functions are in the "**Living with Your Motor Home**" chapter of this manual.

AIR CONDITIONER

(See "**ELECTRICAL SYSTEM**" for Fleetwood Climate Control System)

The roof-mounted air conditioners can operate only when the motor home is connected to 120-volt AC power from either a public utility or the generator. Be sure to turn the air conditioner circuit breaker ON.

NOTE: Your motor home is equipped with a ceiling-ducted air conditioning system. Each roof-mounted air conditioner is connected to its own duct system and is independent of the other air conditioner. For most efficient operation, adjust each vent so that is completely open. If you change the vent opening to regulate air flow, try not to restrict the vent opening to below 70% open. Restricting air flow below this opening will affect the efficiency of the air conditioner.

Each return air duct is equipped with a filter. Check these filters at regular intervals for accumulations of dust that could restrict air flow. To check the filters, remove the return air duct cover with a screwdriver.

For best performance, park the motor home in the shade and close curtains. Close doors and windows and turn the temperature control knob for desired coolness. Refer to the air conditioner manufacturer's instructions for detailed operating and preventive maintenance requirements. Remember that air conditioners use a large portion of your available electric power.

ENTERTAINMENT EQUIPMENT

If additional equipment requiring 12-volt power is installed in the motor home, obtain the 12-volt source from a properly fused battery circuit. Consult an authorized Fleetwood dealer before adding any additional equipment to your motor home.

120-volt VCR (Optional)

The optional 120-volt VCR can operate only when the motor home is connected to 120-volt power from either a public utility or the generator.

120/12-volt Television (Optional Bedroom)

The 120-volt/12-volt televisions can operate from a 12-volt power source (battery) as the motor home is delivered. Care should be taken so the batteries are not drained while using the TV on 12-volt power.

The television can also be operated on 120-volt power from the generator or public utility by removing the 12-volt cord from the rear of the TV and installing the 120-volt cord. Both 120- and 12-volt cords cannot be used at the same time. To use TV on 120-volt power, the cords must be exchanged.

Video Switcher

The video switcher, located on top of the VCR, allows routing of the antenna, cable or VCR signals to both the front and rear TVs independent of each other. You can also use the switcher to record or pass through the signals from the antenna or cable hookup.

TV ANTENNA

The roof-mounted antenna is designed for reception of VHF and UHF television signals.

Before traveling, remember to lower the antenna and secure it to prevent damage to the antenna, motor home roof, or objects in the path of the antenna, such as overhead wires. **DO NOT TRAVEL WITH THE ANTENNA RAISED.**

NOTE: The antenna booster power supply must be turned off to prevent battery drain. A red indicator light will glow when the unit is on.

TV AND RADIO INTERFERENCE

The television and radio systems in your RV have been chosen to provide good performance under varied signal conditions. Occasionally, though, you may experience "ghosts" on TV, "flutter" when listening to FM broadcasts, or other signal interference.

The fault is normally not with your receiver. Neither is your antenna system usually at fault. The idea that antennas, whether amplified or not, "pull in" a signal is a popular misconception. An antenna does not pull a signal out of air by virtue of its "power". The antenna only responds to signals present at the antenna elements. Antennas with boosters only amplify these signals.

Since distance from the broadcast tower is critical to reception clarity, remember that TV and FM signals have a range of only about 75 miles under the best of atmospheric and geographic conditions. The good reception you get at parks located at great distances from broadcast facilities is probably the result of satellite, microwave or other cable distribution systems. The antenna on your RV is no competition for these very expensive installations.

In addition, TV and radio frequency interference results from the electromagnetic fields produced by electric arc discharge. This arcing is found in lightning, vehicle ignition systems, and in 12 volt DC (brush type) motors used

in power vents and furnaces. Note that nearly every DC motor has brushes. Most alternating current (AC) motors do not have brushes, and therefore do not generate the arcing interference. This is why this type of interference is less noticeable in a household environment.

As the signal diminishes with distance and geographical features (mountains, etc.), the effect of electric arc interference may become more and more noticeable. Eventually, the signal will be overcome by the interference. The following suggestions can improve reception:

- Use the "park cable" TV antenna system of your RV in remote areas rather than the roof antenna if the campground provides cable hook-up.
- Turn the television antenna. Sometimes turning the antenna will pick up a stronger signal. Try turning or rotating the antenna throughout its range. You may find your signal in a very unexpected direction.
- With FM stereo signals, switch the unit to MONO, if possible. Some of the phase and noise components of a stereo signal will disappear in MONO mode.
- Reduce the treble setting to reduce background noise. Although not yielding the best high-frequency performance, at least you may be able to reduce the irritation of the distortion and noise.

MISCELLANEOUS APPLIANCES

You may have additional appliances in your unit which operate only when connected to 120-volt power from either a public utility or the generator.

In some cases appliance selector switches are provided on the galley to allow you a selection of appliances yet still remain within the power capacity of the electrical system.

Washer/Dryer Drain Screen

(Optional on selected models)

The removable drain screen which protects the pump from lint and foreign matter needs to be cleaned periodically. See your **Owner's Information Package** for more details.

This page intentionally left blank

MAINTENANCE

Your motor home has been designed to provide you with many years of use with a minimum amount of maintenance. This section will familiarize you with the areas of your motor home that require scheduled care. Time spent taking care of your motor home on a regular basis will pay for itself in extended service and will protect your investment. If you are mechanically inclined and regularly perform routine maintenance and repairs on your car or truck, you may want to do the mechanical work on your motor home yourself. If you prefer, your dealer can perform these services for you. His trained personnel will assure that your motor home is maintained and repaired in keeping with original performance expectations.

This section is intended to provide the owner and operator with a general overview of service and maintenance information for the motor home. Detailed service and maintenance information may be found in the owner's/operator's manuals contained in the **Owner's Information Package**.

While the information in this section is intended to establish proper maintenance and inspection procedures, there may be times when detailed diagnostic and repair procedures may be required. Consult your dealer or an authorized Fleetwood Service Center in these situations.

EXTERIOR

Some exterior parts of your motor home are made of fiberglass. The finish on these parts is durable, but not indestructible. Any material and finish will deteriorate in time. Exposure to sunlight, moisture and airborne pollutants can cause dulling and fading of the finish. Generally, changes in the finish due to weathering are cosmetic — they are on the surface of the part and do not affect its strength. Weathering can take the form of chalking, fading and yellowing.

The best insurance against these effects is routine maintenance. If the finish is not washed and waxed thoroughly, the surface can deteriorate very rapidly. The following maintenance guidelines can help you reduce these weathering effects:

1. When the motor home is not in use, keep the fiberglass surfaces out of the sun or covered with a canvas tarpaulin. Avoid using plastic or other nonporous materials which can trap moisture between the cover and the fiberglass surface.
2. Wash the exterior with a mild detergent monthly, at least. For the best results, use a cleaner formulated for fiberglass, and follow the directions for using the cleaner. **DO NOT use automatic dishwasher detergent, abrasives, bleaches, strong chemicals with acids/bases, or ammonia.**
3. Wax the exterior at least once a year — twice, if possible — with a wax formulated for fiberglass. When waxing, always read and follow the instructions and precautions included with the wax. Some cleaners and waxes are recommended for use on only certain types of surfaces. In some cases, a light rubbing compound may be required to remove the effects of chalking and weathering, or to remove light scratches or nicks. Use only a fine grit compound and follow label directions carefully. **DO NOT** apply rubbing compound in direct sunlight.

Stains

Stains are generally caused by two types of substances — water soluble and non-water soluble. Water soluble stains can usually be washed away with water and mild detergent. Follow the washing with wax.

Non-water soluble stains are usually oil-based. Removal of this type of stain may require the use of highly flammable or poisonous solvents. Refer this type of service to your dealer or an authorized Fleetwood Service Center. Never use strong solvents or abrasives to clean plastic surfaces.

Windows, Doors, Vents & Locks

Keep moving parts, hinges and latches adjusted and maintained. Lubricate with a light oil at least once a year. Check and tighten the screws holding the windows in place as required. Clean screens by gently wiping with a damp cloth or soft flat brush. Not all screens are removable.

Inspect the sealants around doors and windows every three months. See **"Sealant Renewal"** section.

Lubricate locksets in doors and exterior storage compartments at least annually with powdered graphite. If the motor home is located at a beach or is exposed to salt air, more frequent lubrication may be required.

RUBBER ROOF SYSTEM

Cleaning

For normal cleaning, standard household detergents or cleansers may be used. Use a non-abrasive, common household detergent and plenty of water. Be sure to keep the sidewalls wet to reduce streaking. Road tar, tree sap or other stubborn stains can be removed with a soft rag and xylene.

WARNING

XYLENE IS A FLAMMABLE LIQUID. USE EXTREME CARE WHEN HANDLING AND USING. DO NOT EXPOSE TO OPEN FLAME, SPARK OR SMOKING MATERIAL. DO NOT USE IN UNVENTILATED AREA.

Care

The rubber roof itself does not require annual coatings or additional sealants. Periodic washing with soap and water is all that is required.

The rubber roof material can be cut by sharp objects. Use caution when loading sharp articles on the roof. If you add accessories or new equipment on the roof, be sure the installer is qualified to work on the rubber roof material. This is required under the terms of the warranty.

Repair kits are available through your dealer. The roof requires special adhesives and material.

WARNING

RUBBER ROOF MATERIAL IS SLIPPERY WHEN WET.

Sealant Renewal

The adhesives and sealants used in the construction of your motor home were developed to remain waterproof under sustained effects of weather and vibration. However, even the finest materials will eventually dry out and lose their effectiveness under constant heat of the sun and attack by other elements. This section outlines the procedures you must follow to maintain the waterproof integrity of your motor home.

NOTE: Failure to seal could cause serious damage and will affect your warranty coverage.

Your dealer can perform the resealing inspection and work for you. Your dealer also has current information on sealants used in your motor home, and can recommend the appropriate sealants for you if you prefer to do this work yourself. Always use the recommended sealants.

Door, Window, Roof Component And Molding Resealing

Inspect the sealants around windows and doors at least every three months. Also inspect roof vents, other roof components, moldings at front and rear caps, and perimeter molding. If any of the following defects are evident during inspection, the affected areas must be resealed.

Excessive amount of sealant protruding from joints.

Sealant cracked or peeling.

Voids in sealant.

NOTE: Do not seal the bottom flanges of windows and doors. Sealant voids have been intentionally left in the bottom flange to provide exterior drainage in the event of leakage.

If you find any of the above defects:

1. Use a plastic scraper to remove excess sealant.
2. Clean all areas to be resealed with mineral spirits and clean rags.

WARNING

MINERAL SPIRITS IS A FLAMMABLE LIQUID. USE EXTREME CARE WHEN HANDLING AND USING. DO NOT EXPOSE TO OPEN FLAME, SPARKS, OR SMOKING MATERIAL. DO NOT USE IN UNVENTILATED AREAS.

Make sure that all areas to be resealed are absolutely dry before new sealant is applied.

INTERIOR

Fabrics

Interior appointments such as draperies, bedspreads, mattress covers, upholstery and wall pads are manufactured from high quality synthetic materials and should be dry cleaned only. Frequent vacuuming will keep them free of dust and dirt. Minor spills should be cleaned up quickly to avoid staining. The affected area should be blotted, not rubbed, to prevent the stain from working deeper into the fabric.

WARNING

DO NOT USE LACQUER THINNER, NAIL POLISH REMOVER, CARBON TETRACHLORIDE, SPOT REMOVER, GASOLINE, OR NAPHTHA FOR ANY CLEANING PURPOSE. THESE PRODUCTS MAY CAUSE DAMAGE TO THE MATERIAL BEING CLEANED, AND MAY BE HIGHLY FLAMMABLE OR POISONOUS.

Cutting Block

The pure oil hand rubbed finish ensures natural lasting beauty (no wood sealants are used) and may be cleaned by using soap and water. Do not immerse board in water, store above sink containing water or expose to continuous sunlight.

Counter Tops

Corian Top Care

Since Corian is a non-porous material, many food and household chemical stains wipe off with a sponge and soapy water. Stubborn stains like coffee, grape juice, ink and food coloring rub off with abrasive household cleaner.

Laminate Top Care

For cleaning laminate surfaces, use a mild dishwashing liquid with warm water. Use a soft cloth for both washing and drying.

Do not use abrasive cleaners, steel wool, or gritty cleaners or damage will occur to the surface.

Walls And Ceiling Panels

The paneling and the ceiling of your motor home may be any of several finishes and textures. Never use harsh detergents or abrasive cleaners on walls or ceilings. Most surfaces will clean with a soft cloth moistened with mild liquid detergent in warm water. Do not use large amounts of water which could saturate the material.

Bathtub And Plastic Shower Stall

Some cleaners attack the plastic causing it to discolor and become brittle. The following cleaners have been tested and approved when mixed with water: Distilled vinegar, mild dishwasher detergent, or liquid deodorizing cleaner. Avoid cleaners with any level of abrasives, acetone or MEK (methyl ethyl ketone).

Floors And Carpeting

Vinyl flooring requires only washing and periodic waxing. Vacuum carpeting regularly, and clean it with a

quality carpet cleaner. Do not use water or waxes mixed with water on wood floor.

Engine Access

The top of the engine may be accessed for service by removing the engine cover.

WARNING

WHEN INSTALLING THE ENGINE COVER, BE SURE THE COVER IS FULLY SEATED ON THE GASKET SEAL AND SECURED BY THE COVER SCREWS OR CLAMPS. DO NOT ALLOW CARPETING, FLOOR MATS OR OTHER MATERIAL TO INTERRUPT THE SEAL BETWEEN THE COVER AND THE ENGINE COMPARTMENT. IF THE ENGINE COVER IS NOT INSTALLED CORRECTLY, ENGINE EXHAUST GASES COULD LEAK INTO THE PASSENGER COMPARTMENT CREATING A SAFETY HAZARD. IF THE ENGINE MUST BE RUN WITH THE ENGINE COVER OFF FOR MAINTENANCE PURPOSES, BE SURE THE VEHICLE INTERIOR IS ADEQUATELY VENTILATED.

CONOLAM® SIDEWALLS

The sidewalls of this motor home are built with Conolam®. Conolam® is a very dense fiber and polymer material that is strong, light weight and water-resistant. Its high strength permits a thinner wall cross section while providing strength superior to most wood products.

The cabinets and other components attached to the motor home sidewalls are attached with rivets rather than screws. Since the Conolam® material is about the same thickness as sheet metal, screws do not hold well, and may pull through the material. For this type of material, rivets are an ideal fastener.

If you want to attach items to the interior walls, YOU MUST USE RIVETS. A supply of these rivets is included in your motor home. The rivets can be installed with a hand-operated riveting tool such as the Arrow® E-Z Pull® Model RH200. This and similar tools are available in most hardware stores and home improvement centers.

CAUTION

Do not use any type of screw to attach items to either the interior or exterior of your motor home. Due to the thickness of the Conolam®, ordinary screws do not hold well. The use of screws may damage the interior or exterior wall surface.

When you install a component, carefully mark the hole location and drill a 3/16" hole where the rivet is to be located.

If you need additional rivets, contact your Fleetwood dealer.

MAINTENANCE CHECKLIST

For your convenience, a maintenance checklist is included in this manual. This comprehensive list is the most up to date available at the time of publication. Options and accessories usually have their own owner/user manuals that often contain added maintenance instructions. Consult these manuals as required.

LAMPS AND BULBS

Interior — 12-volt

Ceiling single incandescent	GE 1141	12V
Ceiling double incandescent	GE 1141	12V
Driver/Passenger dome light	GE 1003	
Bedroom/Living Room reading lamps	GE 1076F	12V
Range hood	GE 912	12V
Dinette decor light	GE 1141	12V
Bedroom soffit lights	GE 5312	
Bedroom reading lamps	GE 1383	12V

Interior — 120-volt

Bedroom table lamps	GE 3-Way	120V
Bathroom vanity lamp	40W G16CL	120V

Exterior

	STANDARD		WIDEBODY
Headlight, halogen high-low beam	GE H9004	12V	Sylvania HBS 9007 12V
Turn signal lights, amber	GE 193	12V	Sylvania 3157 NA 12V
Front clearance lights	GE 67DP	12V	GE 67DP 12V
Side marker lights	GE 194	12V	GE 194 12V
Mirror turn signal lights	GE 1895	12V	GE 1895 12V
Porch lights	1003	12V 15cp	1003 12V 15cp
Entry step light	GE 193	12V	GE 193 12V
Rear clearance lights	GE 193	12V	GE 193 12V
Back-up lights	GE 1156	12V	GE 1156 12V
Stop/tail/turn lights	GE 1157	12V	GE 1157 12V
Licence plate light	Truck-lite 19206	12V	GE 5312 12V
Center brake light	N/A		512V2W
Fog Light	N/A		GE 4415 12V

EXTERIOR SEALANT RECOMMENDATIONS

Windshield 3M #SG-4799 black

Self-leveling Roof Sealant..... Schnee-Moorehead #5504 champagne beige
LaSalle Deitch #MS-102 champagne beige

Window Sealant Dow Corning 999 clear
Colormetrics 42120 clear
Schnee-Moorehead 5732 clear

This page intentionally left blank

This page intentionally left blank

MOTOR HOME STORAGE

STORAGE CHECKLISTS

The following checklists will help you perform the steps necessary to prepare your motor home for storage. Use the checklist that applies to the storage conditions you anticipate.

These checklists do not include every detail required, and you may want to expand them to suit your needs. Contact your dealer for additional suggestions suitable to your climate and storage conditions, particularly extremes of hot and cold.

SHORT-TERM STORAGE

(less than 60 days)

- Wash the motor home exterior and underside. Hose off accumulations of mud and road salts.
- Thoroughly clean the interior of the motor home, including carpets, counter tops, lavy, tub and shower, and galley.
- Inflate tires to maximum rated cold pressure.
- Park the motor home as level as possible front to rear and side to side. Block wheels front and rear, and leave the parking brake OFF.
- Check the charge in the battery. Recharge as necessary.
- Remove battery cables. Refer to **Chassis Owner's Manual** for proper removal and installation sequence. Clean terminals, top and sides of batteries and battery boxes. Reinstall cables, dress with a plastic ignition spray.
- Use battery disconnect switch/es, if equipped.
- Drain holding tanks, toilet, and fresh water tank.
- Turn off water pump and water heater master switches.
- Turn off LP gas at tank valve.
- Turn off refrigerator and furnace.
- Turn off all range and oven burner valves and pilot valves (if equipped).
- Remove all perishables from refrigerator and galley cabinets. Block refrigerator open to reduce odor buildup. An open box or tray of baking soda in the refrigerator will help absorb odors.
- Open closet doors, drawers, and cabinets so air can circulate.
- Slightly open (1/4") roof vents, at front and rear for ventilation. If the motor home is being stored below freezing, close and cover all vents to prevent entry of snow or small animals and insects.
- Close and lock all windows. Be sure vent fan and range hood fan switches are off.
- Cover exterior appliance vents (water heater, furnace, range hood, refrigerator) to prevent insects from getting in. Be sure to remove all covering material before using appliances or vents.
- Cap or close holding tank drain, city water inlet and fresh water fill spout.
- Turn off all radios, TVs, interior and exterior lights.
- Close curtains and/or mini-blinds, and pull shades.
- Disconnect the 120-volt power cord, and store in compartment.
- Cover tires with cloth, plywood, or aftermarket tire covers.
- Prepare generator (if equipped). Refer to generator operating manual included in your **Owner's Information Package**.
- Run the engine for about 15 minutes every 30 days. Turn the vehicle air conditioner ON during this run. Check engine oil, transmission fluid and coolant levels.

LONG-TERM STORAGE

(Over 60 Days)

- Perform all steps as required for short-term storage.

- Run engine to normal operating temperature. Operate air conditioner to lubricate compressor seals. Drain engine oil, replace filter, refill engine with fresh oil.
- Remove windshield wiper blades and store inside the motor home.
- Charge and remove both the vehicle and auxiliary batteries. Store them in a cool, dry place, and check the charge and water level every 30 days. For batteries with non-removable vent caps, check the specific gravity of the electrolyte periodically with a hydrometer or boost charge every three months. If the specific gravity is being checked, recharge the battery when it reaches 1.220. The time it takes the battery to reach 1.220 depends on its condition and the temperature. The colder the storage area, the slower the battery will self-discharge. A normal time between charges is three months.
- Remove, clean and replace air conditioner filters. Cover the air conditioner shroud(s).
- Cover the windows on the inside with foil, cardboard, paper, etc., to reduce curtain, drape, and carpet fading.
- Cover the external refrigerator, range hood and furnace vents. This will prevent mice, insects, and some spiders that are attracted to LP gas from building nests that can disrupt the air flow and keep appliances from functioning properly.
- Remove batteries in clocks or other battery-powered devices.
- During extended periods of storage, gasoline may deteriorate due to oxidation. This can damage rubber and other materials in the fuel system such as carburetor, accelerator pump, diaphragms, and carburetor inlet valves. It may also clog small orifices. Commercially available gasoline fuel stabilizers may be added whenever actual or expected storage periods exceed 60 days. Follow the additive manufacturer's instructions. Operate the vehicle regularly during the storage period to mix and circulate the anti-oxidant agent throughout the fuel system.
- Check tire inflation pressures every 30 days. Maintain maximum rated cold inflation pressure.

- Check the sealant around all roof and body seams and windows. Reseal if necessary. See "**Sealant Renewal**" section.
- Lubricate all locks and hinges as described in the "**MAINTENANCE**" chapter.
- Remove high grass or weed growth.

WINTERIZATION

Thoughtful planning and preparation for the winter season can help eliminate equipment failures and breakdowns, and can extend the life of your motor home and its systems. Your dealer can advise you concerning specific winterization procedures and products for your climate area or the areas through which you will be traveling. Your dealer may also provide winterization service for all appliances and systems in the motor home. The following is a check list if you prefer to perform these procedures yourself:

- Check engine coolant level and antifreeze protection. Drain and flush engine cooling system and add antifreeze to protect the system to the lowest expected storage temperature or at least -20° F.
- Service and winterize the generator (if equipped) as outlined in the generator operating manual included in your **Owner's Information Package**.
- Winterize the LP gas system. Your LP dealer or service station will perform this for you.
- Winterize all appliances as outlined in the individual operator's manuals.
- Remove snow accumulations as often as possible.

WATER SYSTEM WINTERIZING

Read this section completely before performing winterization.

- Remove water filter cartridge, if equipped, and install the winterizing plug.
- Drain the fresh water tank by opening the water tank drain valve located inside the chassis passthrough compartment. Leave the valve open.
- Turn water pump on (12-volt power must be on). Open a cold water faucet. When the flow of water stops, turn the pump off.

- Open water faucets, then open the drain valves on HOT and COLD water pipes. Leave these valves open.
- Drain the water heater by opening the drain plug at the bottom of the heater and the safety valve at the top.
- Flush the toilet. Operate toilet sprayer, if equipped.
- Drain the shower head by opening the valve. Let all water drain out the tub spout. Leave the valve open.
- When each faucet has been drained, close all faucets, water line drain valves and the fresh water tank drain valve, install the water heater plug and close the safety valve.
- Drain the waste water system by following the normal procedure for draining the holding tanks. (See **PLUMBING** chapter).
- Apply silicone lubrication to the knife valve actuator rod(s).
- Be sure ALL water from ALL plumbing fixtures has been drained.
- Open low point drains. (See **PLUMBING** chapter).

CAUTION

DRAINING THE WATER SYSTEM ALONE WILL NOT PROVIDE ADEQUATE COLD WEATHER PROTECTION. IF THE MOTOR HOME IS TO BE UNHEATED DURING FREEZING TEMPERATURES, CONSULT YOUR DEALER FOR THE BEST WINTERIZING PROCEDURE FOR YOUR CLIMATE. YOUR DEALER CAN WINTERIZE YOUR MOTOR HOME FOR YOU OR CAN SUPPLY YOU WITH ONE OF THE SPECIAL ANTIFREEZES WHICH ARE SAFE AND APPROVED FOR USE IN RV WATER SYSTEMS. FOLLOW THE INSTRUCTIONS FURNISHED WITH THE ANTIFREEZE.

WARNING

DO NOT USE AUTOMOTIVE OR WINDSHIELD WASHER ANTIFREEZE IN THE MOTOR HOME WATER SYSTEM. THESE SOLUTIONS MAY BE HARMFUL IF SWALLOWED.

- Close holding tank drain valves, low point drain valves and fresh water tank drain valve.
- Pour approximately five gallons of approved non-toxic antifreeze into the fresh water tank.

- Turn the water pump master switch ON.
- Open each cold water faucet, run the water pump and let about a cup of antifreeze solution flow continuously through each faucet. Close each cold water faucet.
- Flush the toilet until the antifreeze solution flows continuously. Release flush mechanism.
- Winterize the water heater according to the instructions provided with the water heater operating manual. Winterize the hot water lines by opening each hot water faucet, allowing antifreeze solution to flow continuously, and then close each faucet. This will require considerably more antifreeze solution, and you may choose to do this step before winterizing the cold water lines so you can recycle the solution.
- When filling the plumbing systems with antifreeze, be sure to open and operate all fixtures and valves allowing the antifreeze solution to flow freely.
- Pour one cup of antifreeze solution down each drain.
- Install all protective caps:
 - Water tank fill
 - City water inlet cap
 - Waste tank drain outlet cap

REACTIVATING THE MOTOR HOME AFTER STORAGE

If the motor home was properly and carefully prepared for storage, taking it out of storage will not be difficult. The following procedure check list assumes that you stored the motor home with care. If you didn't, and extensive freeze damage or other serious deterioration has occurred, please consult your dealer or an authorized Fleetwood Service Center for advice.

- Thoroughly inspect the outside of the vehicle. Look for animal nests in wheel wells, under the hood, in air cleaner or in other out of the way places.
- Remove all appliance vents, ceiling vent and air conditioner coverings. Be sure all furnace, water heater, and refrigerator openings are clear and free of debris or insect nests, webs, etc.
- Open all doors and compartments. Check for

animal or insect intrusion, water damage, or other deterioration.

- Check all chassis fluid levels — engine oil, engine coolant, power steering fluid, brake fluid, transmission fluid, rear axle oil.
- Check charge level in batteries. Refill and recharge as necessary. Reinstall batteries if necessary. Be sure cable ends and terminals are clean and free of corrosion.
- Check tire pressures. Reinflate to specified cold pressure.
- Remove covering from inside windows.
- Open vents and windows for ventilation.
- Be sure engine instruments indicate proper readings. Run engine up to operating temperature. Shut engine down. Check all fluids. Top up if necessary.
- During engine run, check the operation of headlights, tail-lights, turn signals, backup lights, clearance lights, license plate light, emergency flashers. Operate the vehicle air conditioner. If air conditioner does not work, or unusual sounds occur, have the system checked by a qualified air conditioner technician.
- Drain, flush, and sanitize the fresh water system as outlined in the “**PLUMBING**” chapter. Inspect the drain hose for leaks. Replace if necessary — repairs are usually not effective.
- Install a new water filter cartridge (if equipped).
- Operate all faucets and fixtures in the fresh water system. Check for leaks at all joints and fittings. Repair if necessary.
- Check 12-volt circuit breakers and inspect fuses.
- Operate all 12-volt lights and accessories.
- Install new batteries in battery-operated devices. Check operator's manual for each device for additional requirements.
- Test carbon monoxide, LP gas and smoke detectors.
- Check monitor panel operation.
- Open and operate vents and vent fans, including the range hood fan.
- Inspect the 120-volt electrical system — power

cord, converter, all outlets, and any exposed wiring. If defects are found, refer service to your dealer or an authorized Fleetwood Service Center.

- Prepare the generator for operation following instructions in the generator operating manual in your **Owner's Information Package**.
- Start and run generator.
- Operate 120-volt appliances and air conditioners. Be sure to uncover air conditioner shroud(s).
- Inspect the LP gas system and check for leaks as described in the “**LP GAS SYSTEM**” chapter. If the LP tank shows signs of rust or corrosion, have it inspected by a qualified LPG technician.
- Operate each LP gas appliance. Observe all burner/pilot flames for proper color and size. In any case, have the LP gas regulator adjusted for proper pressure by a qualified technician.
- Inspect and clean the interior.
- Check the sealant around all roof and body seams and windows. Reseal if necessary. See “**Sealant Renewal**” section.
- Lubricate all exterior locks, hinges, and latches.
- Reinstall windshield wiper blades. Check wiper/washer operation.
- Wash and wax the exterior. Inspect the body for scratches or other damage. Touch up or repair as necessary. Flush the underside thoroughly.
- Run thorough operational checks of steering, brakes, engine and transmission. Operate vehicle slowly during these checks to allow sufficient circulation of fluids and reseating of components.

Your motor home should now be ready for a new traveling season. If you choose, your dealer can double check your preparation and correct any defects or make any necessary adjustments.

This page intentionally left blank

This page intentionally left blank

MAINTENANCE CHART

	A	B	C	D	E	F	G	H	I	J
Wash exterior		●								
Wax exterior							●			
Lubricate and adjust exterior locks, hinges and window mechanisms							●			
Lubricate power step mechanism	●	●						●		
Lubricate TV antenna	●					●		●		
Check all exterior sealants, around windows, doors, sidewall seams, windshield, lamps, all exterior openings and roof components. Re-seal if necessary.	●				●			●		
Inspect and clean fuel-fired appliance vents: Water heater, refrigerator, furnace.	●			●			●	●		
Inspect and test safety equipment: Fire extinguisher, LP, CO and smoke detectors, and GFI receptacles.	●			●						
Service appliances and equipment: refrigerator, roof air conditioner, furnace, generator	●								●	
Inspect generator exhaust system	●		●					●		
Inspect LPG system including leak check	●	●						●		
Sanitize fresh water tank	●				●					
Clean drapes and interior fabrics	●					●				
Check exterior lamp operation	●					●				
Re-torque U-bolts (Mor-Ryde equipped only)									●	
Chassis										●
Fire Extinguisher Inspection							●			
Smoke Detector Operation		●								
LPG Detector Operation		●								

A - Start of Season
B - Each Trip or Monthly
C - Every 8 Hours
D - Weekly
E - Every 3 Months

F - Every 6 Months
G - Each Year
H - End of season
I - At Specified Mileage or Interval
J - At Specified Mileage for Heavy Duty Service

This page intentionally left blank